

x2

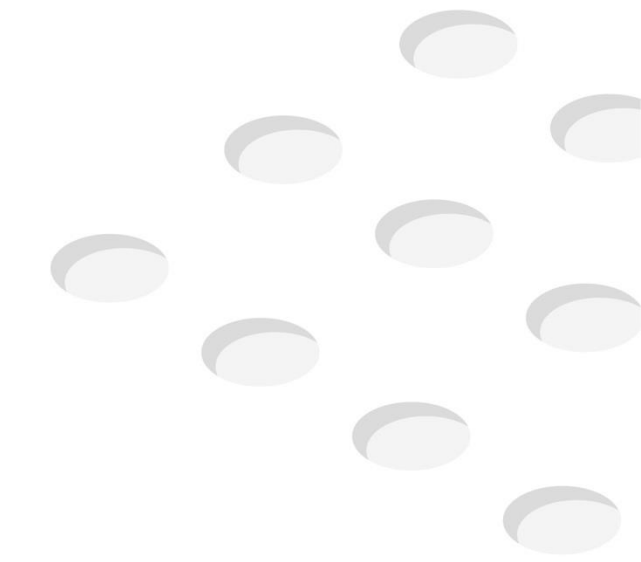

x4

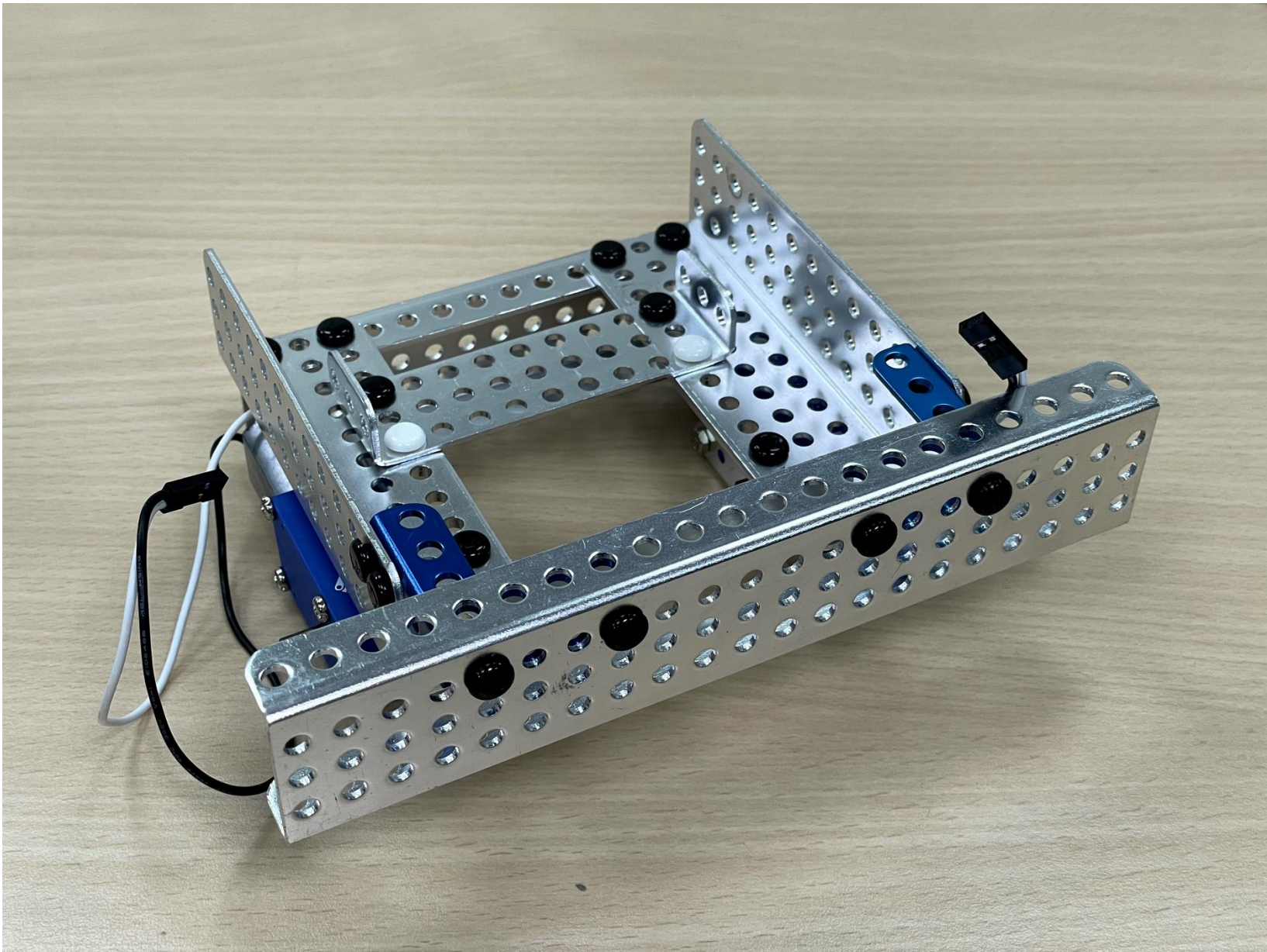

x1

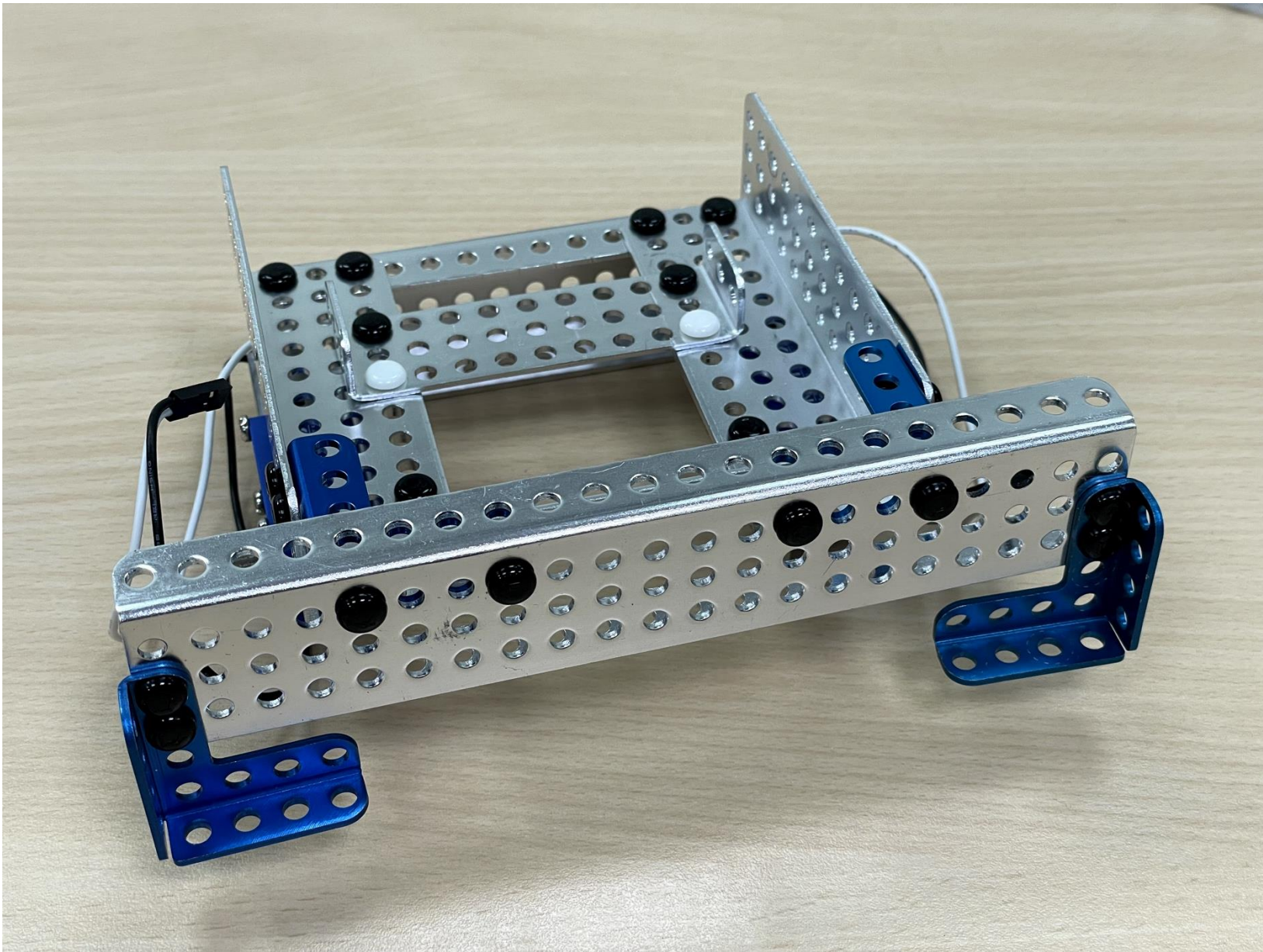

 x4



x2

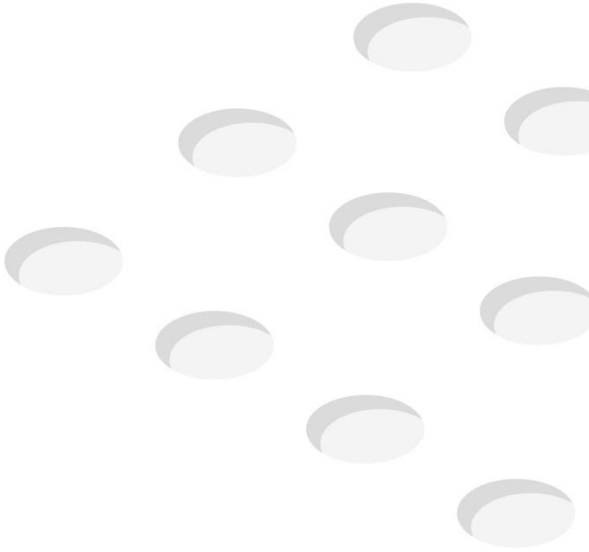
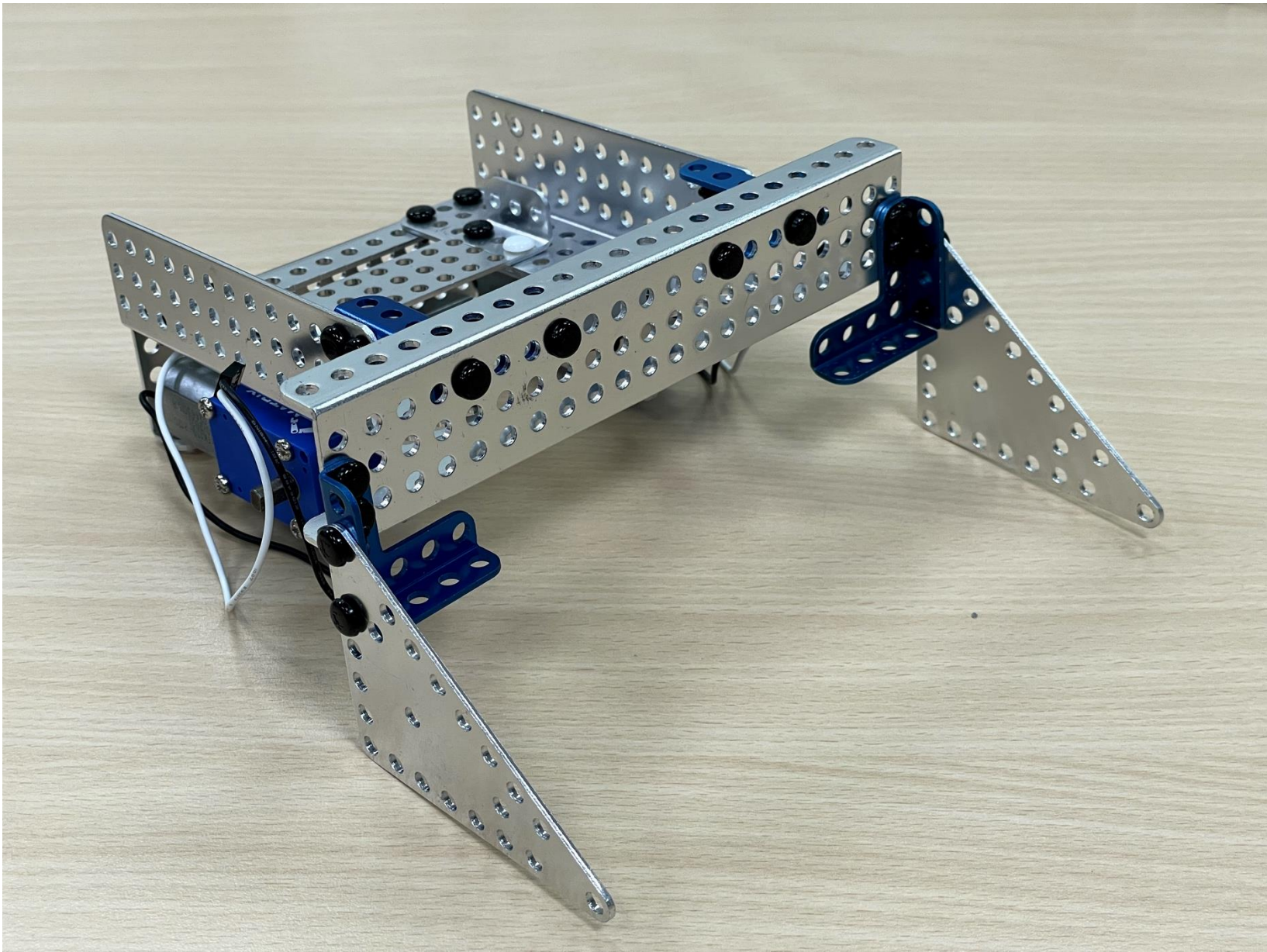

x4



x2

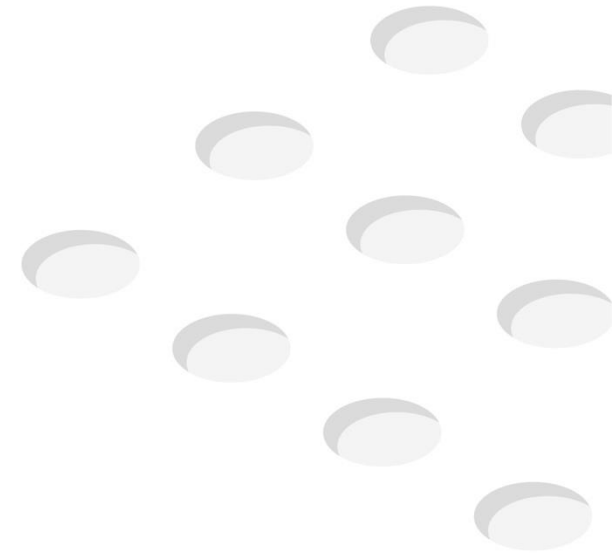
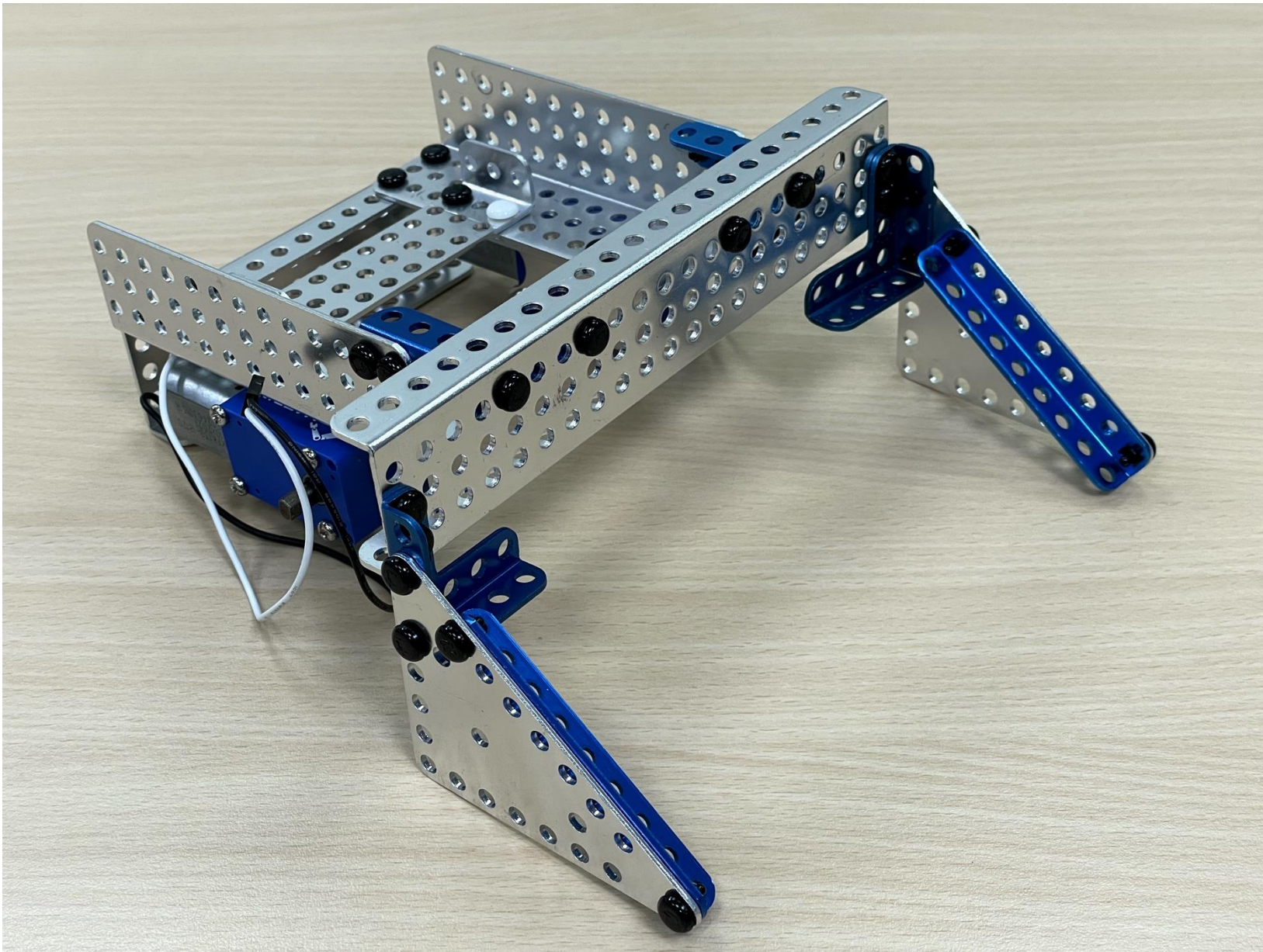

x4

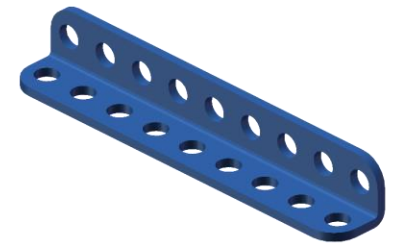

x2

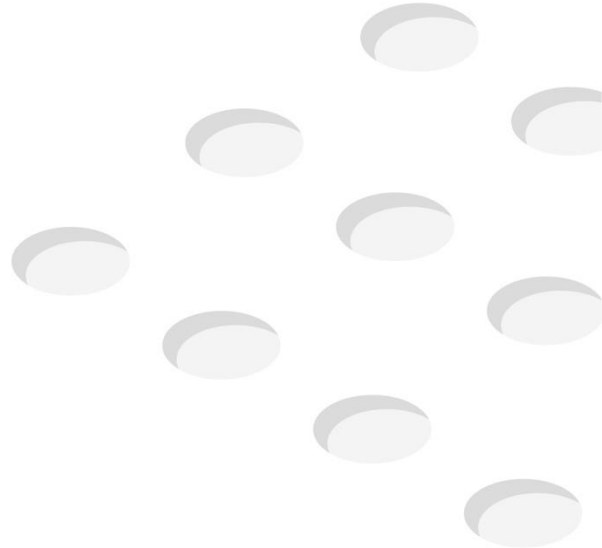
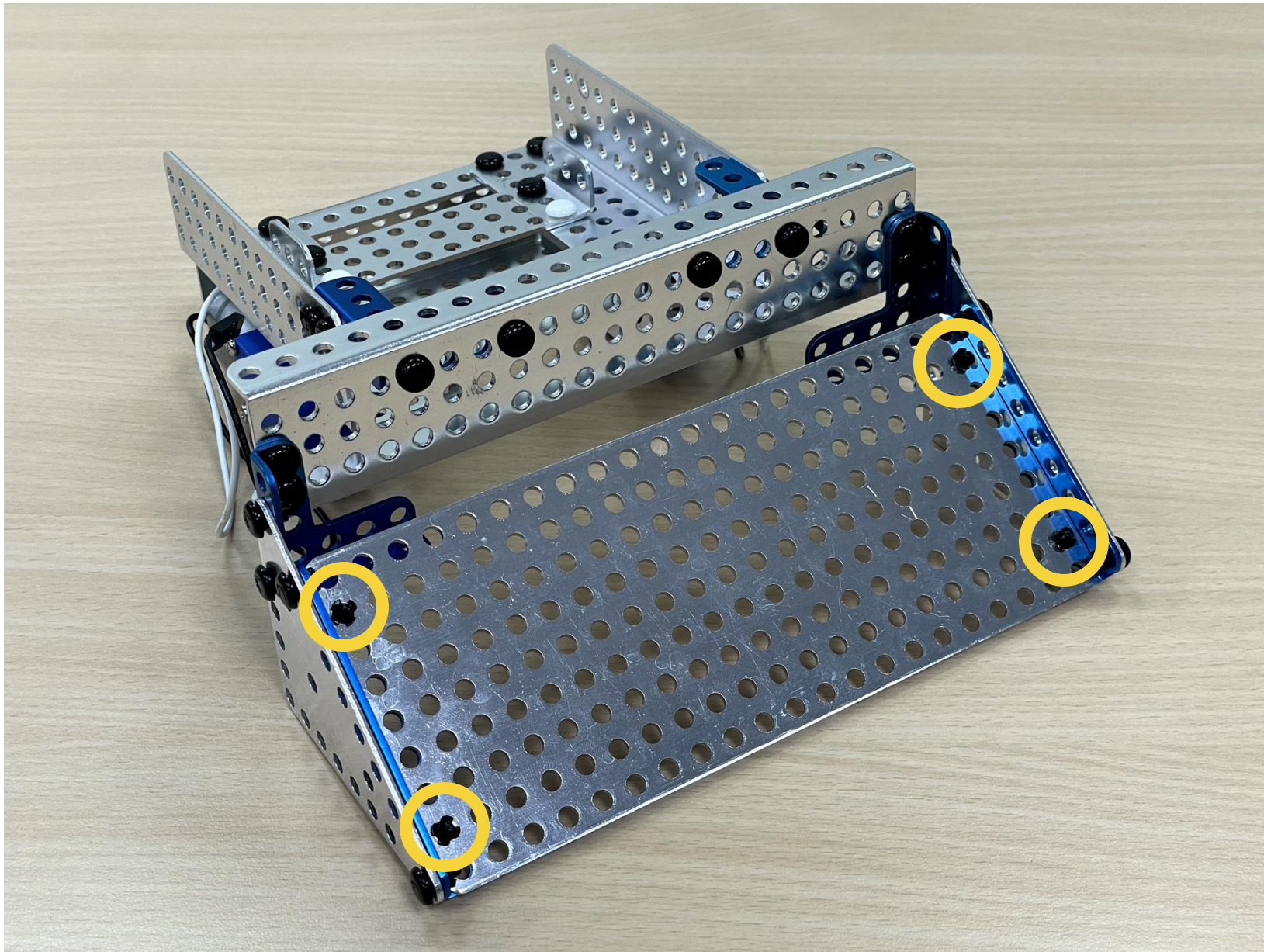

x4

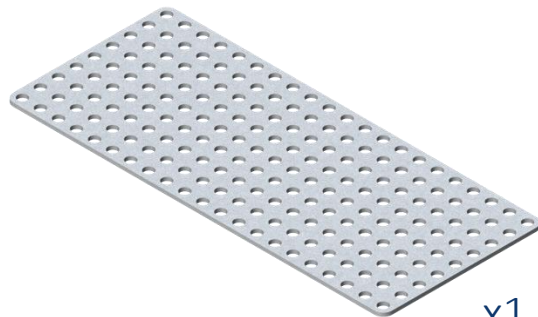

x1

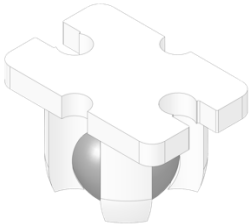
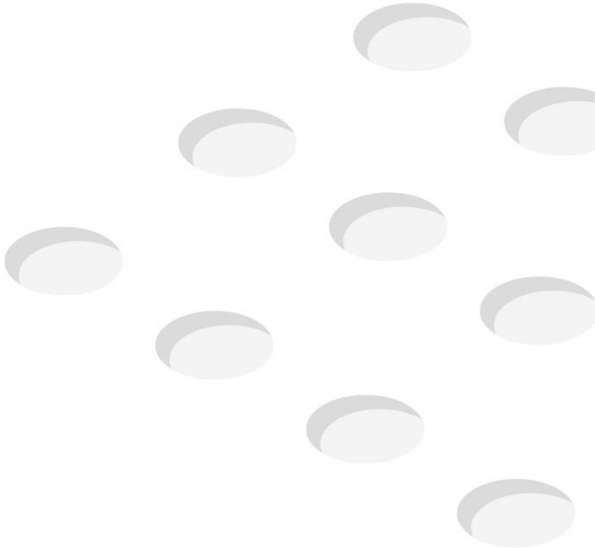
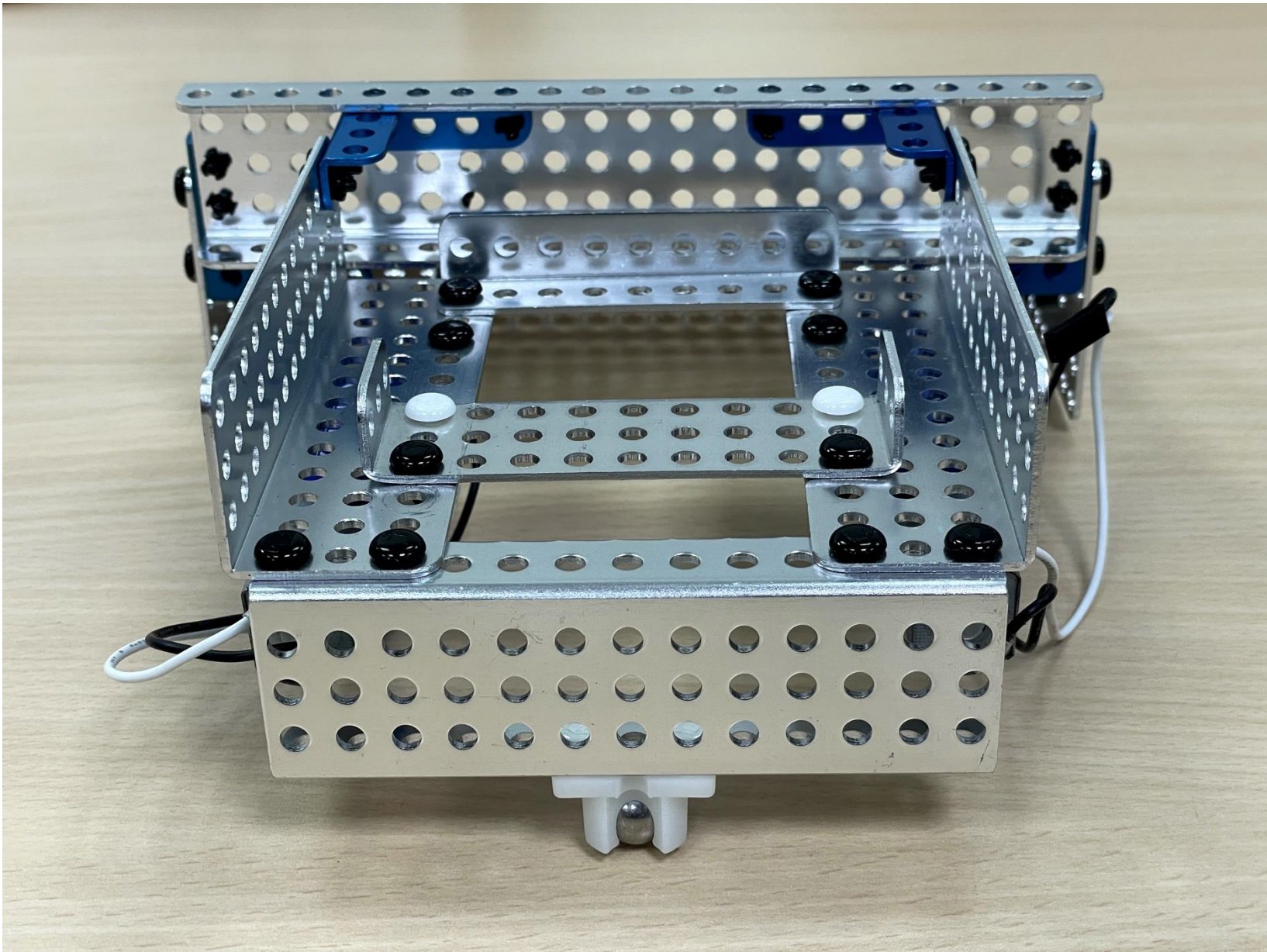

x1



x2

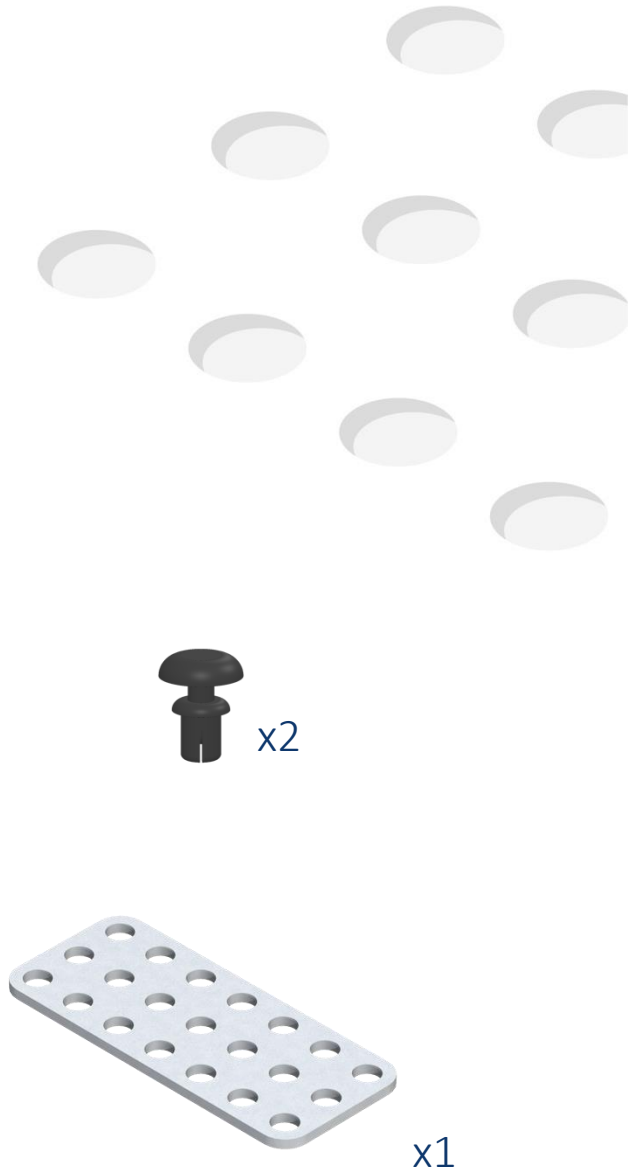
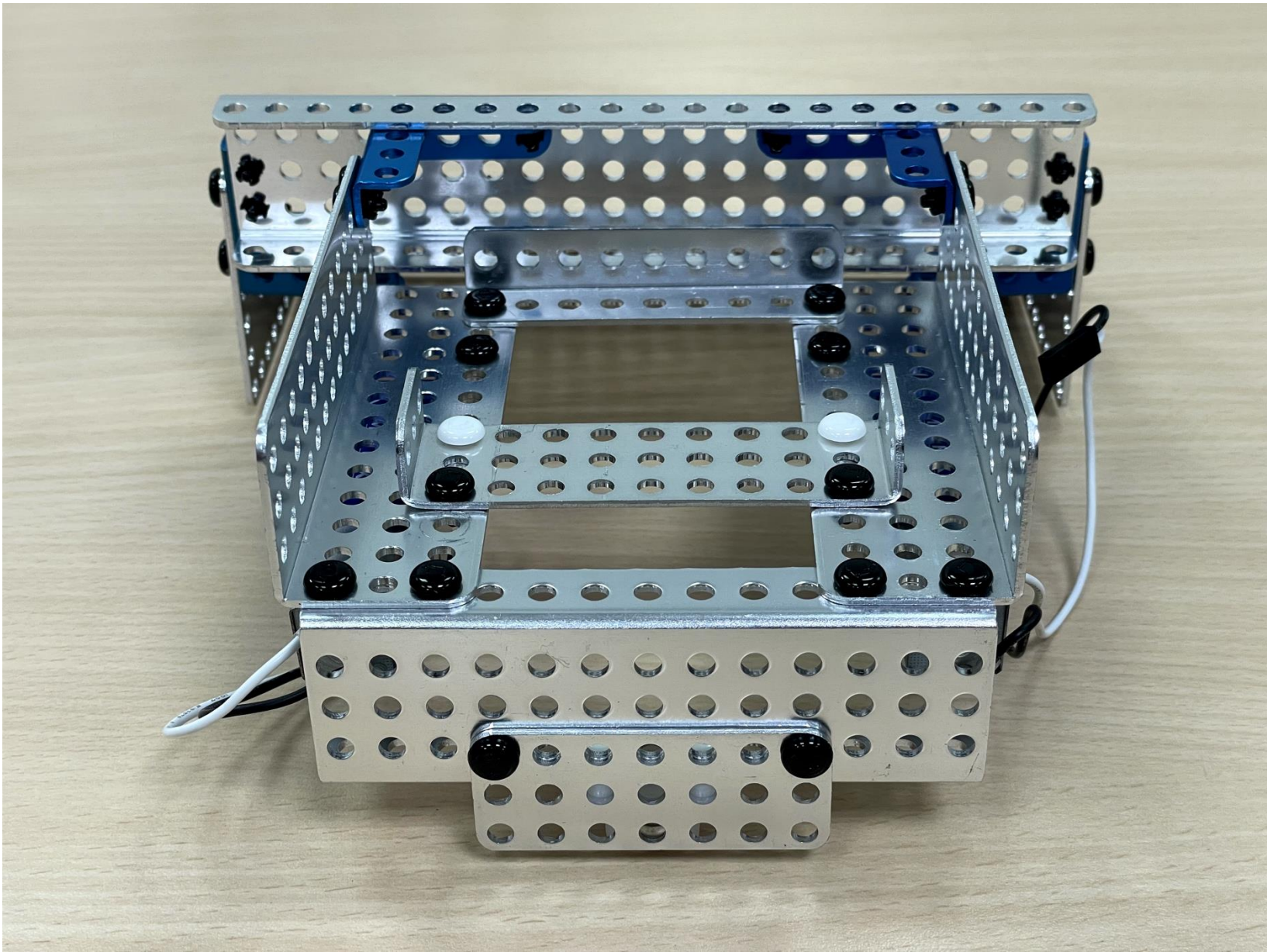

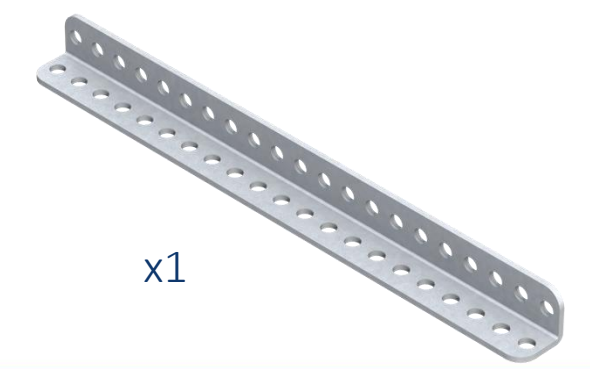
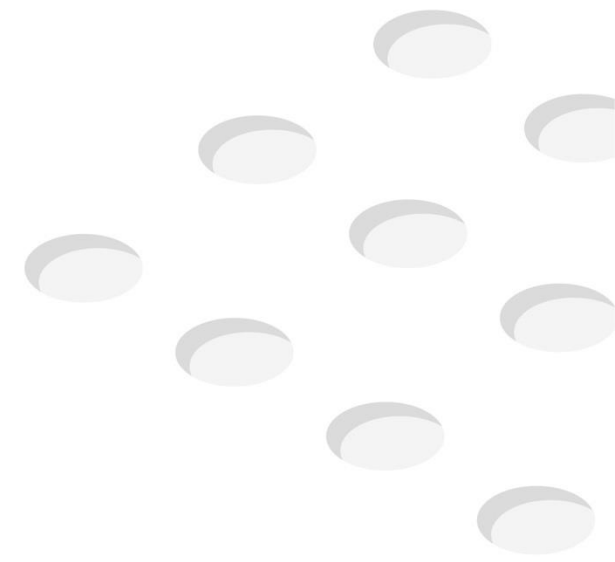
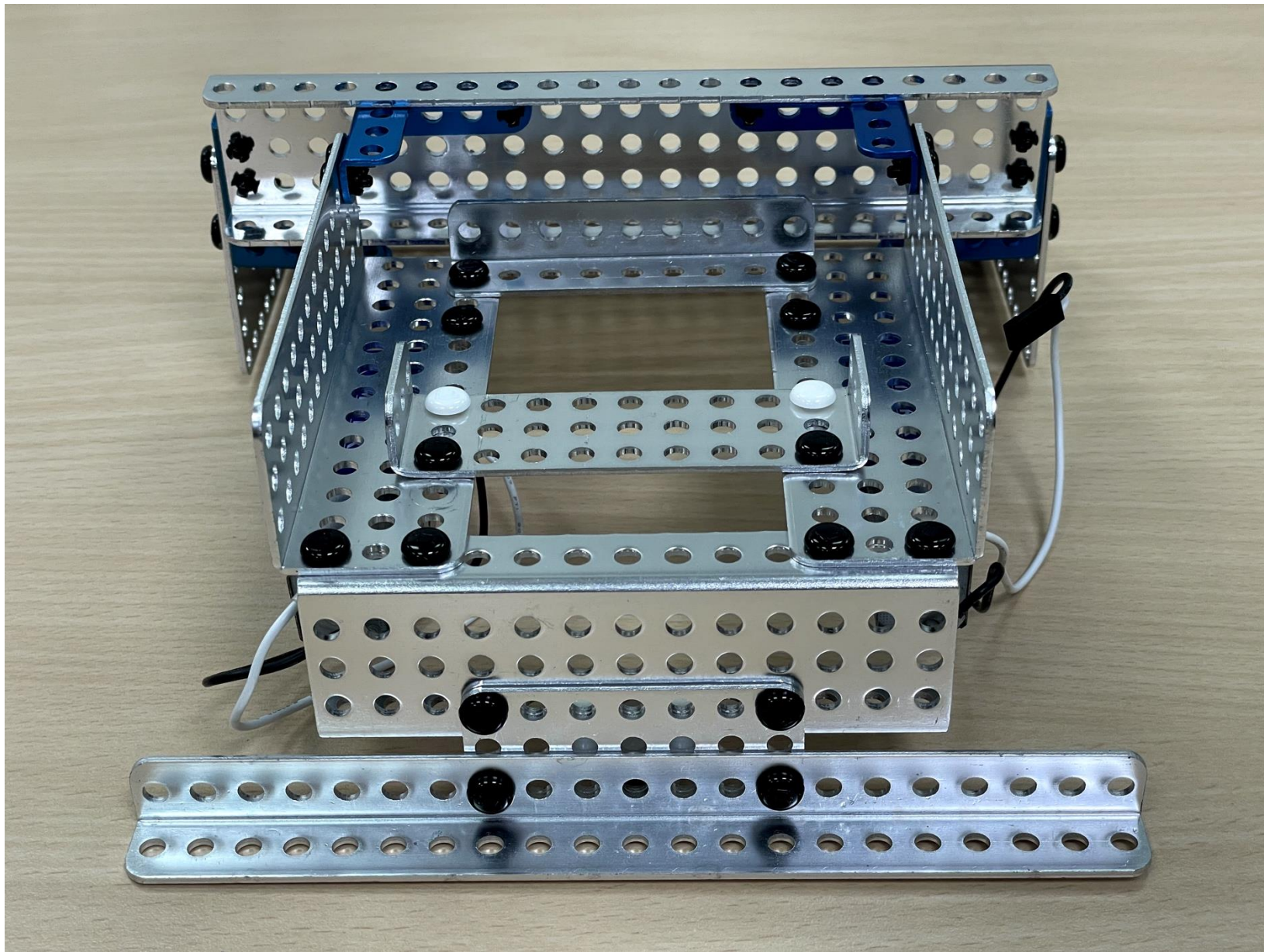

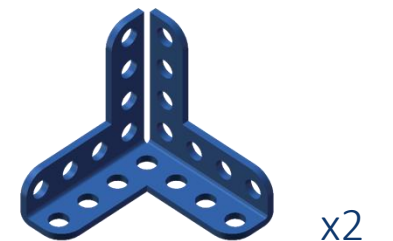
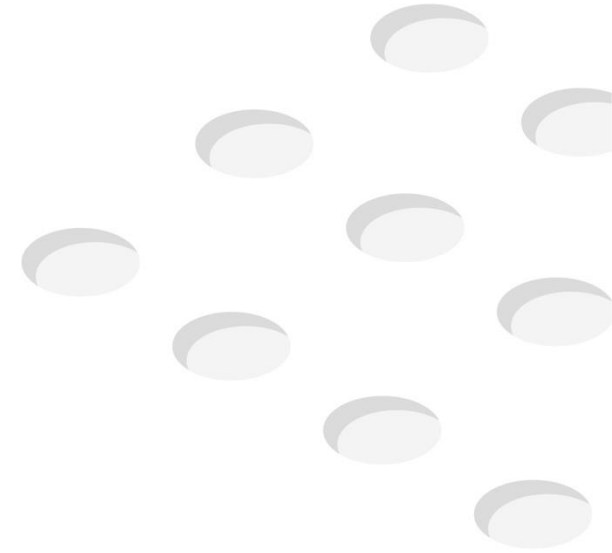
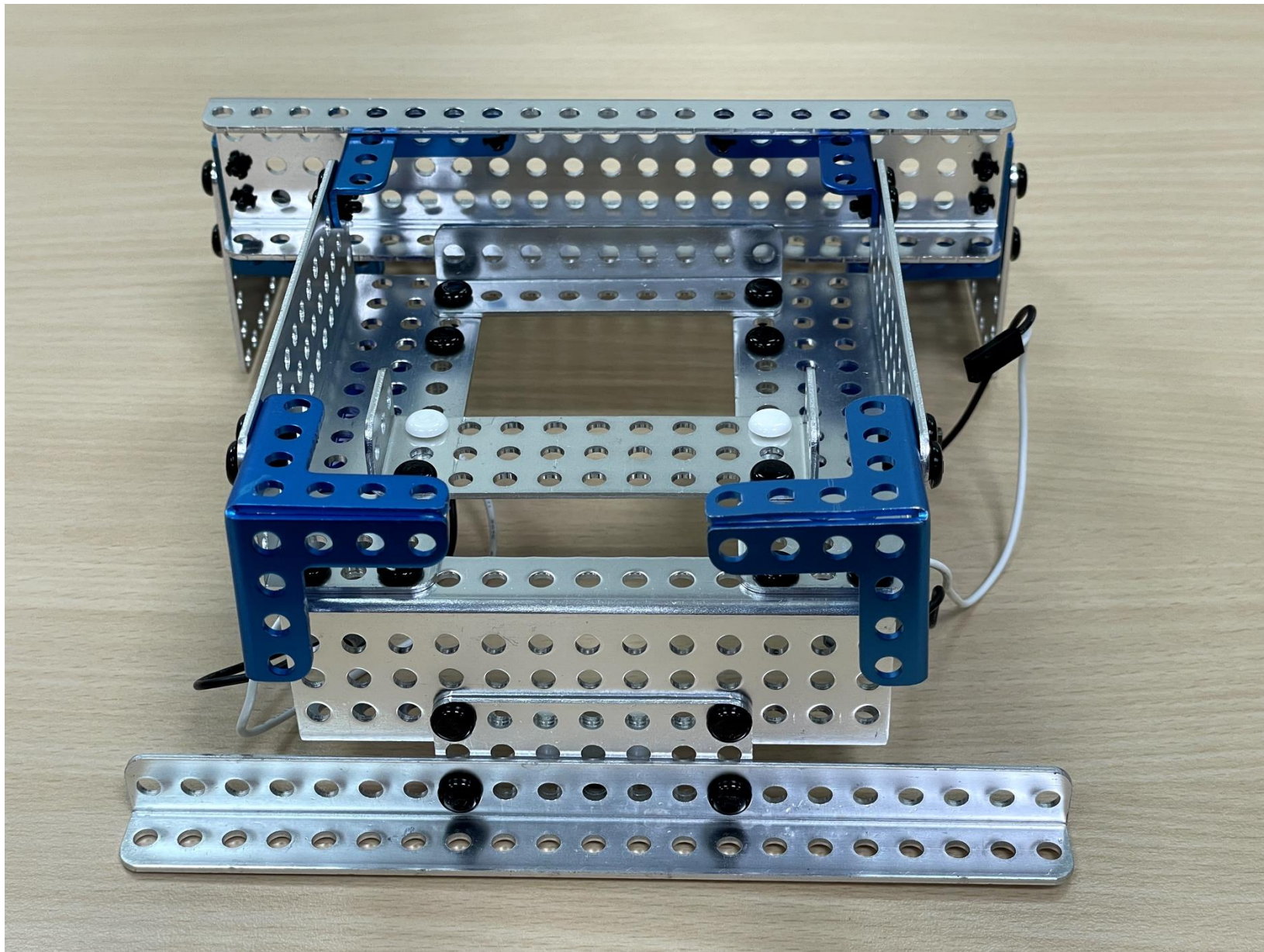

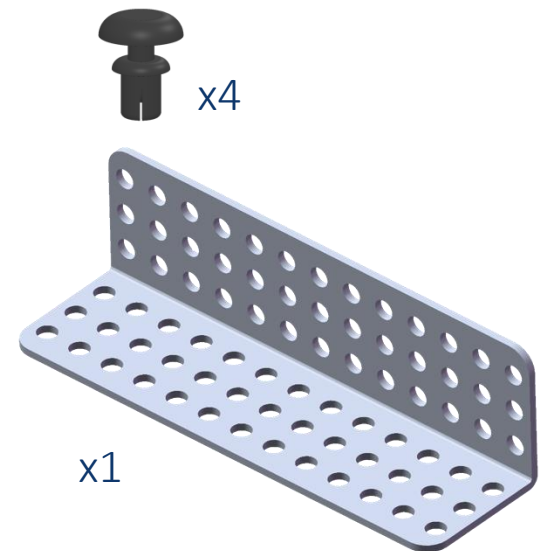
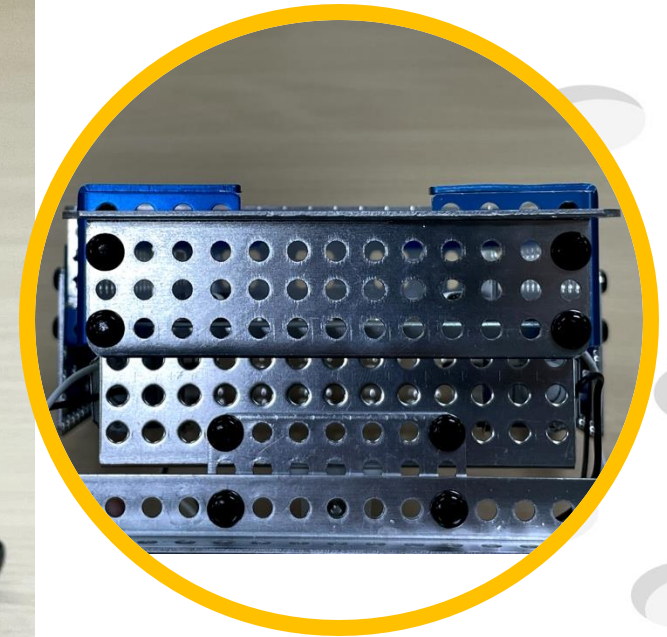
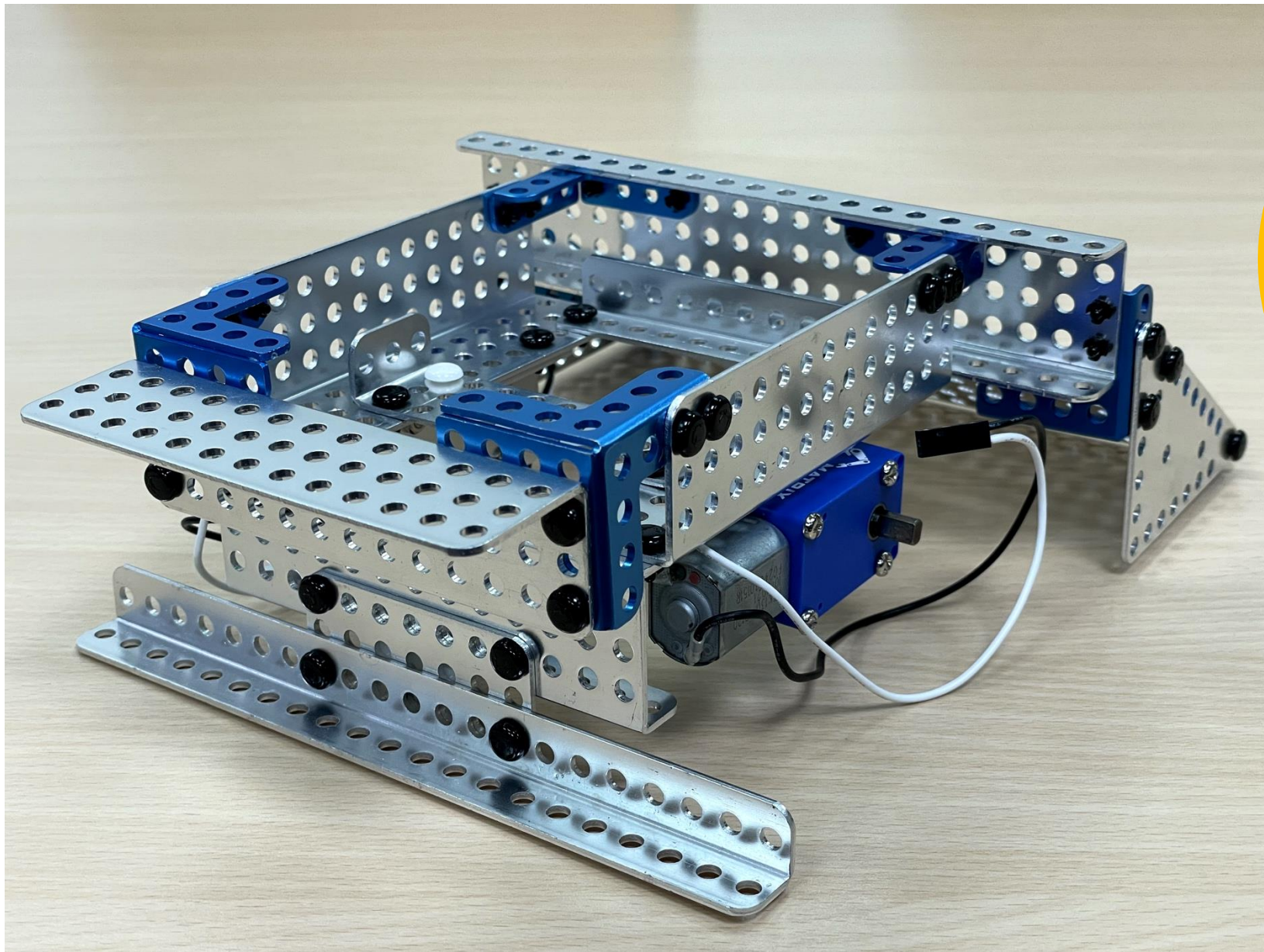

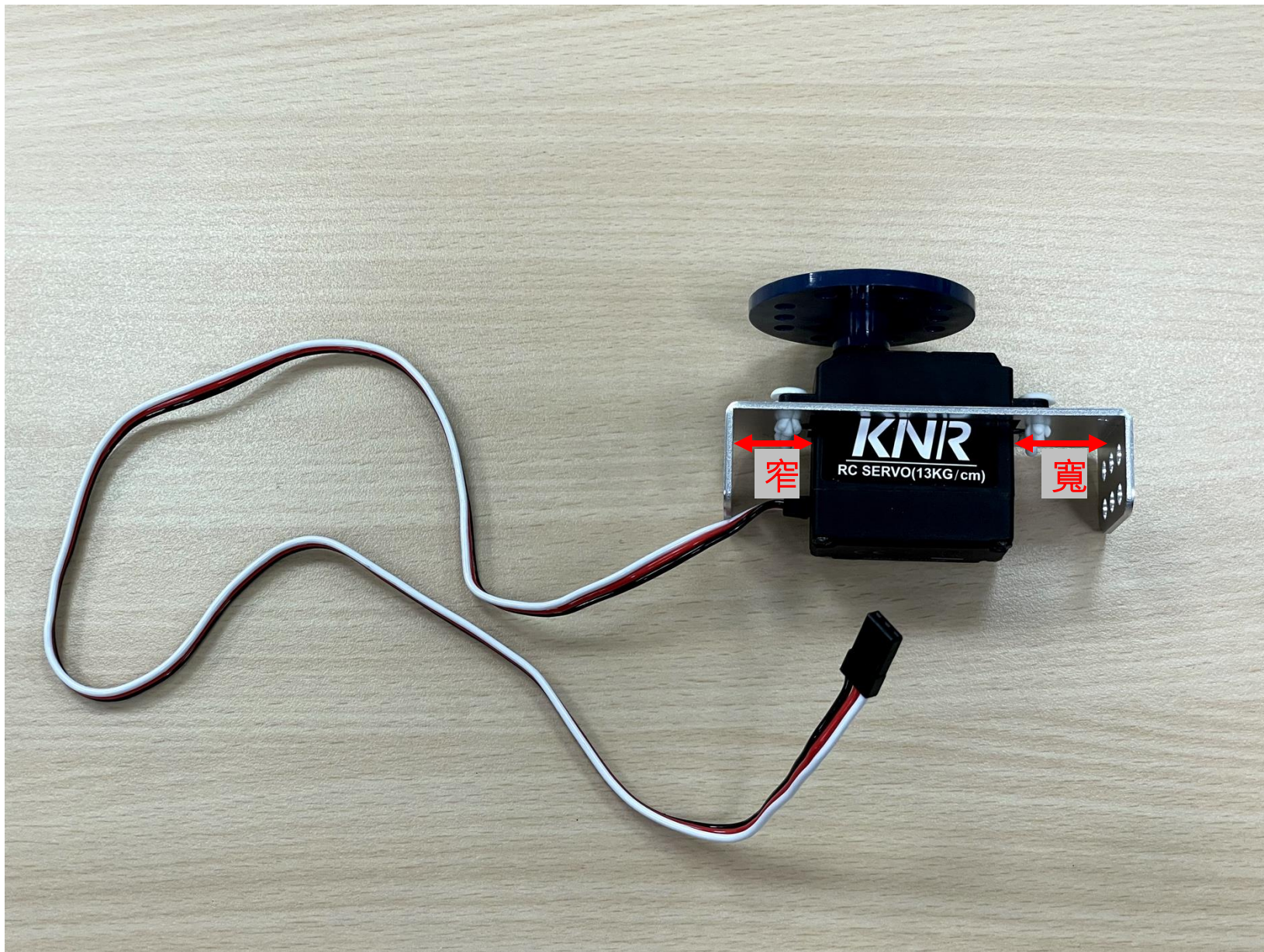

舵盤靠近支架較窄的那側

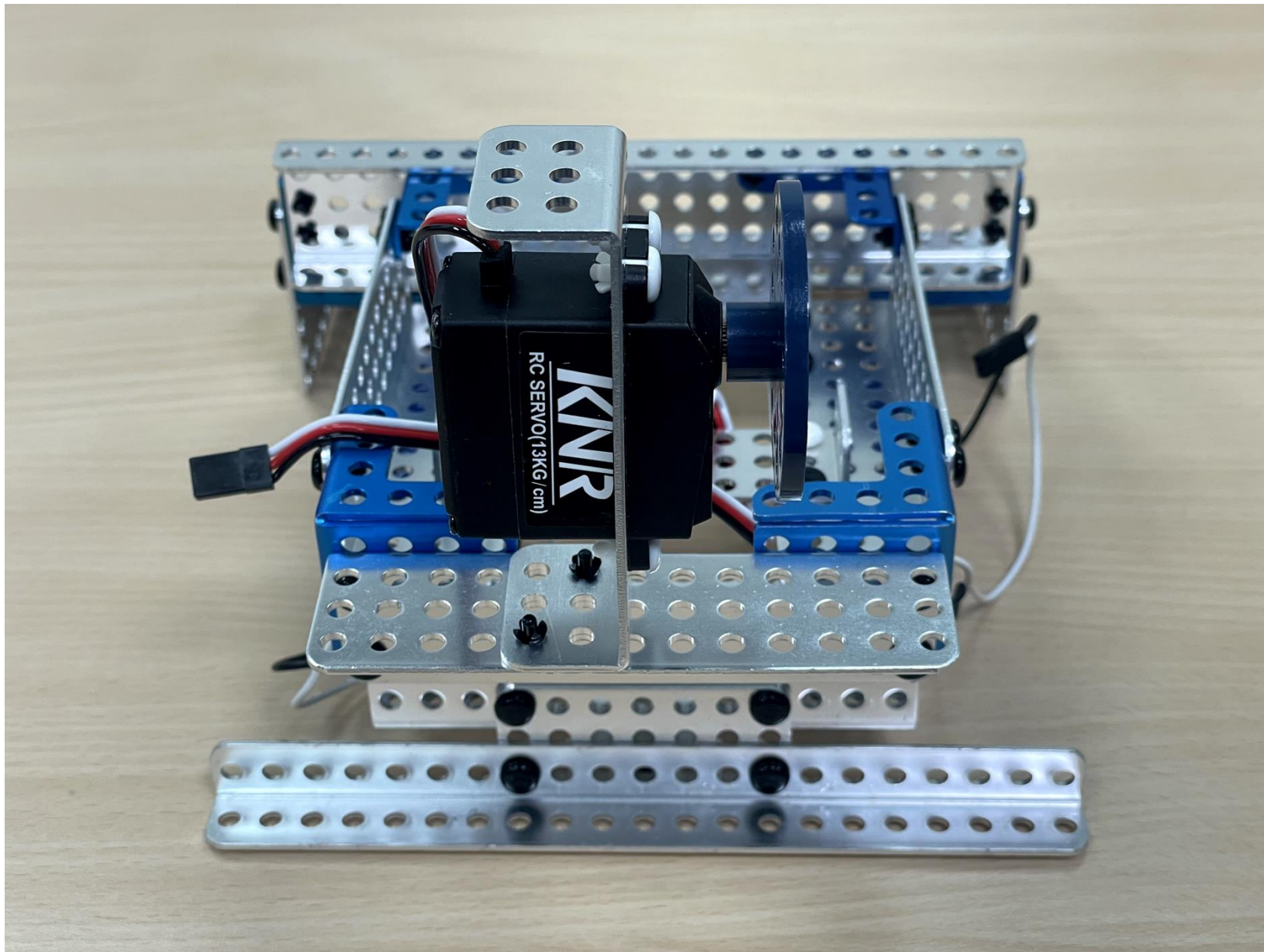

x2

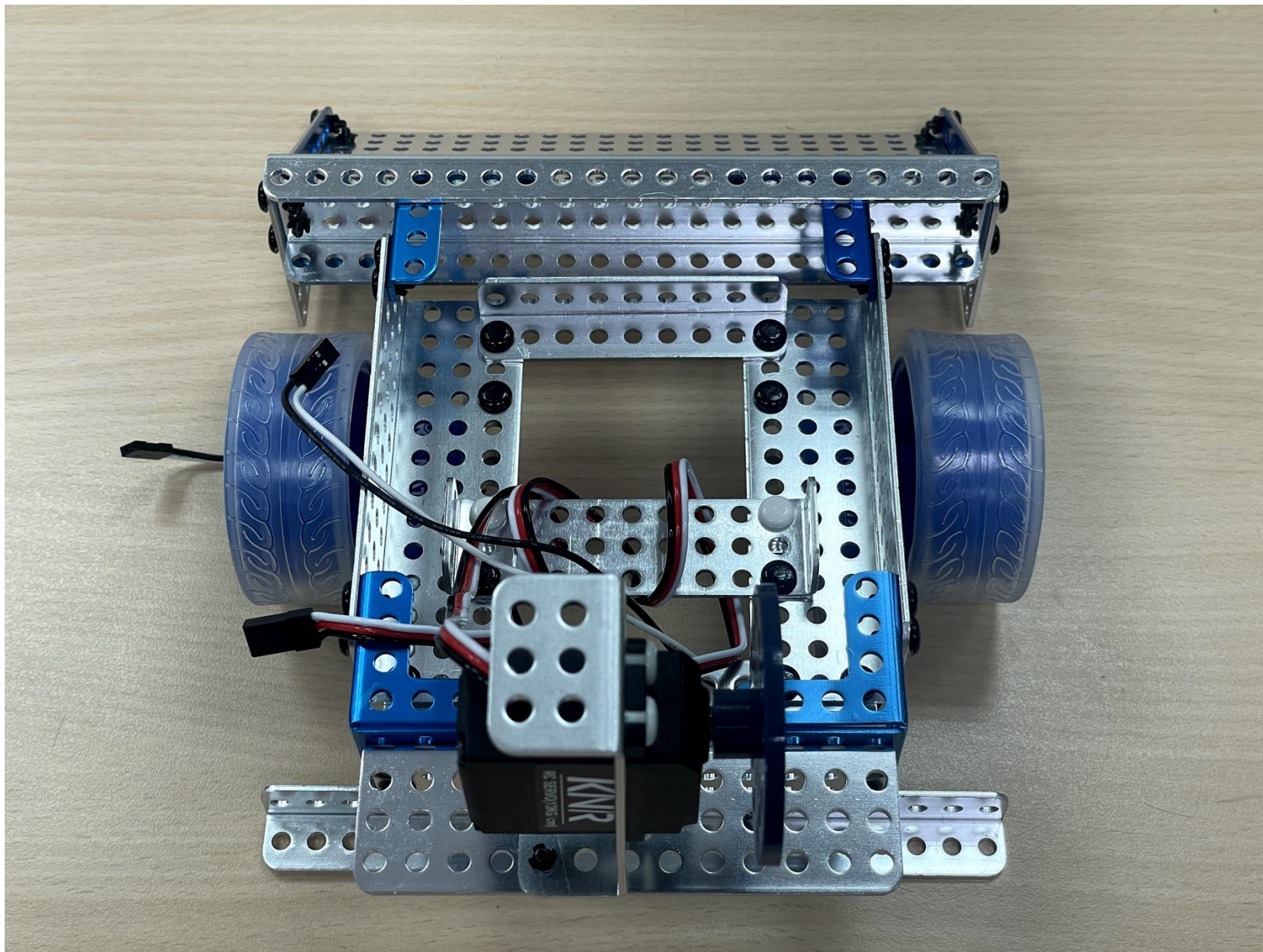

大伺服馬達的線較長，
可纏繞在3x9折邊平板上



x2

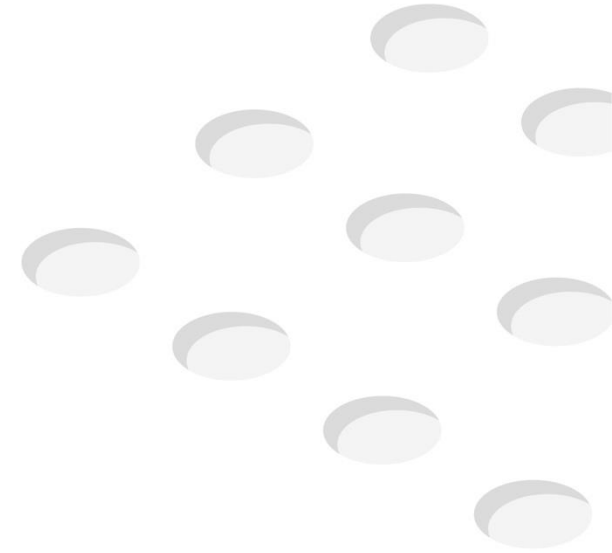

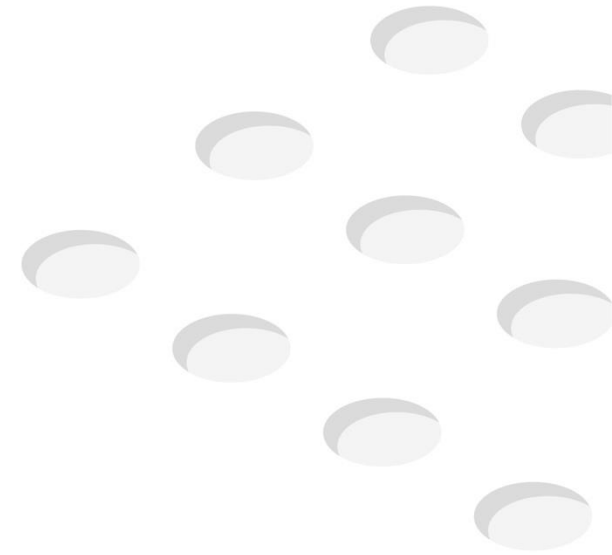
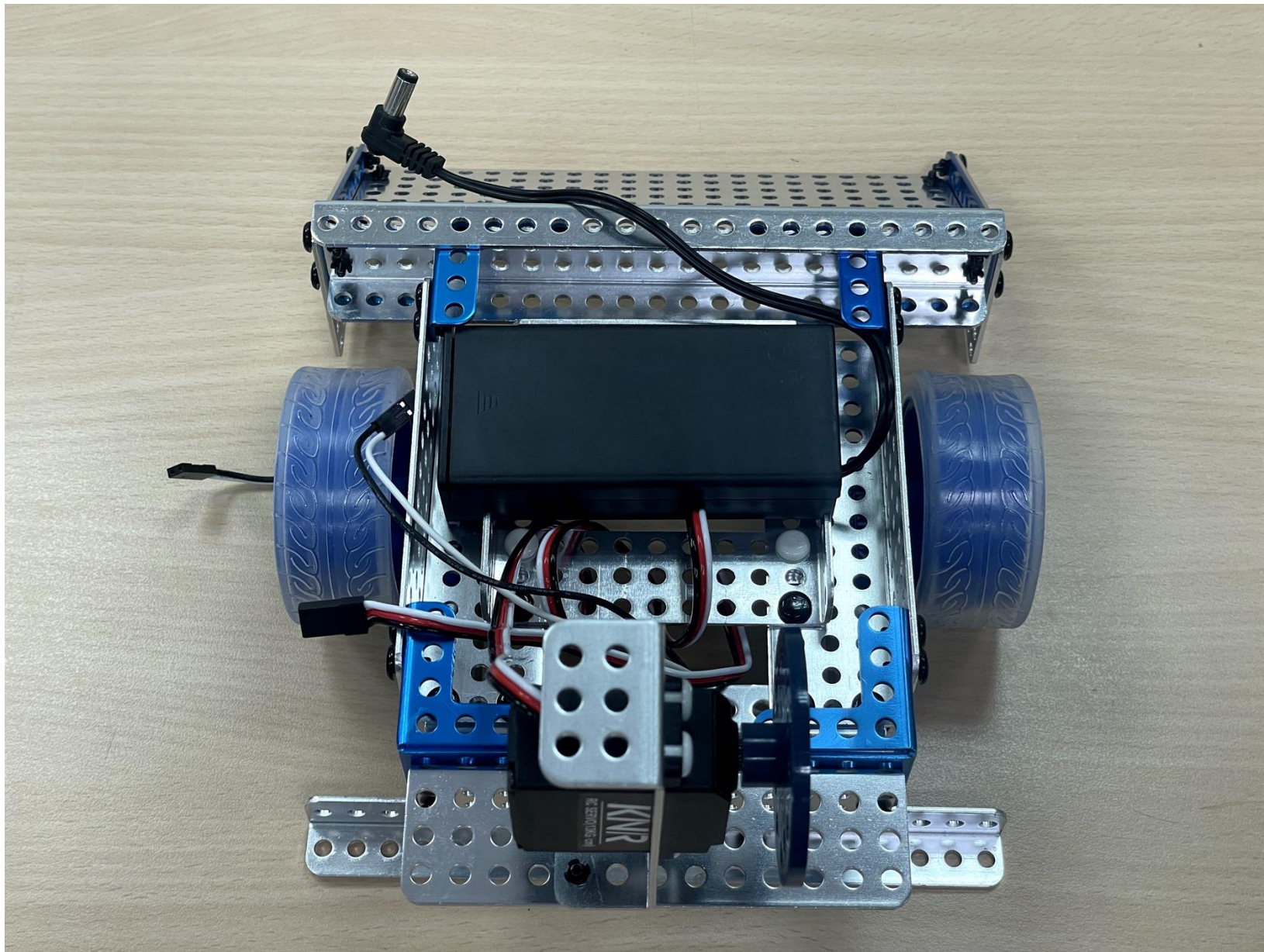

STEAM EDUCATION, FUTURE TECHNOLOGY.

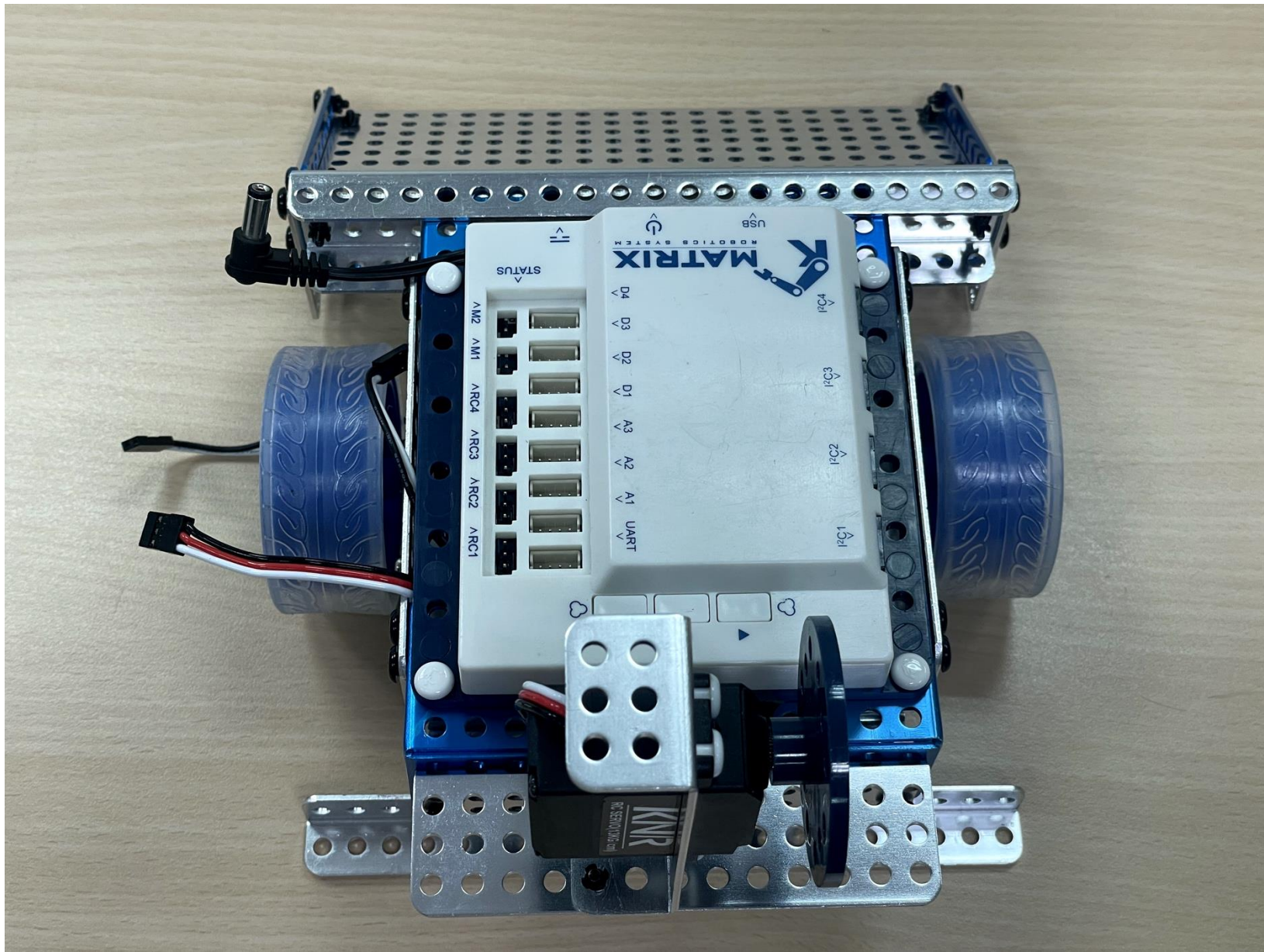

x4

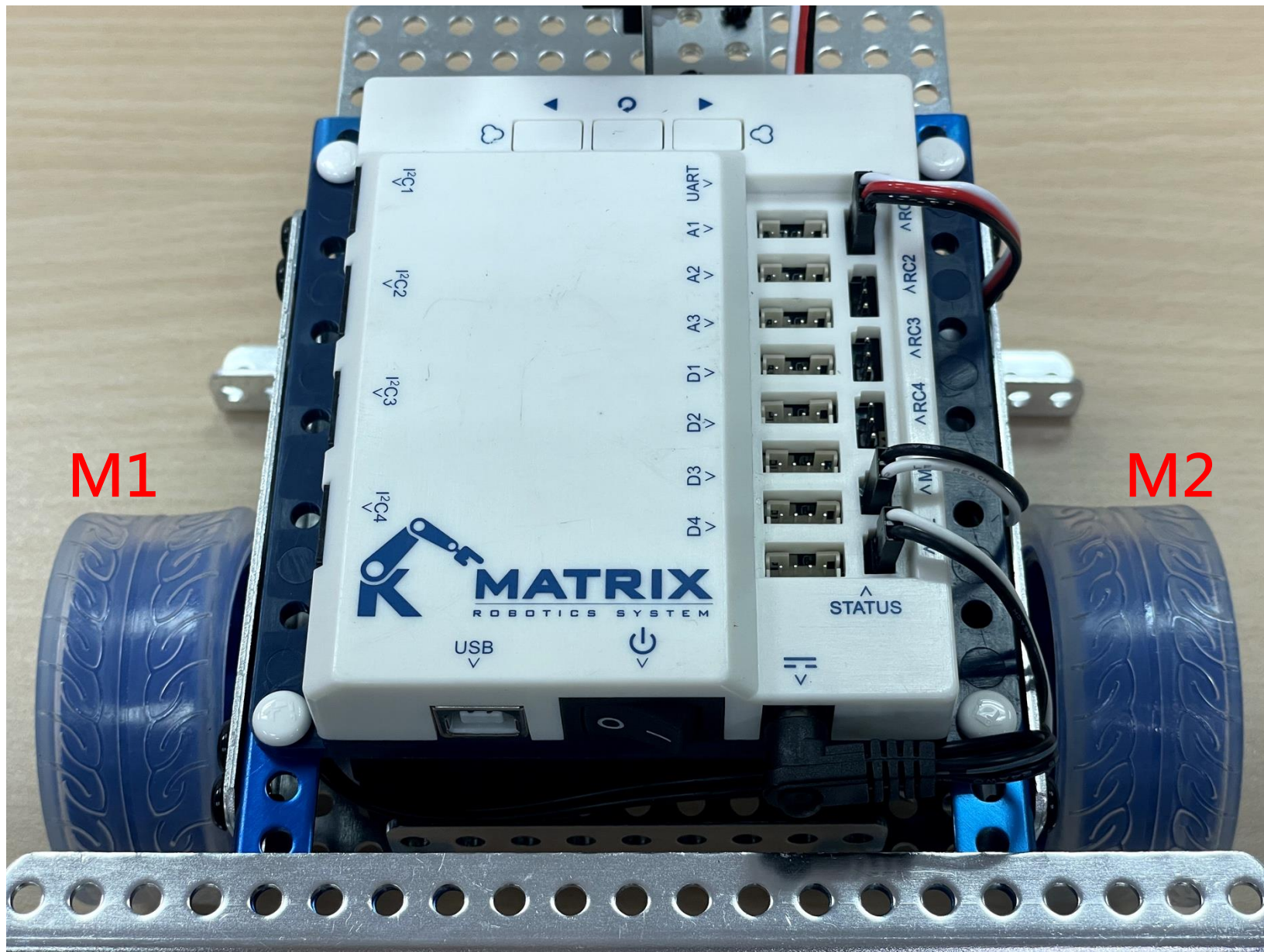

左輪馬達→M1
右輪馬達→M2
大伺服馬達→RC1
(深色GND靠^)

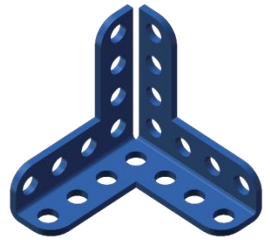
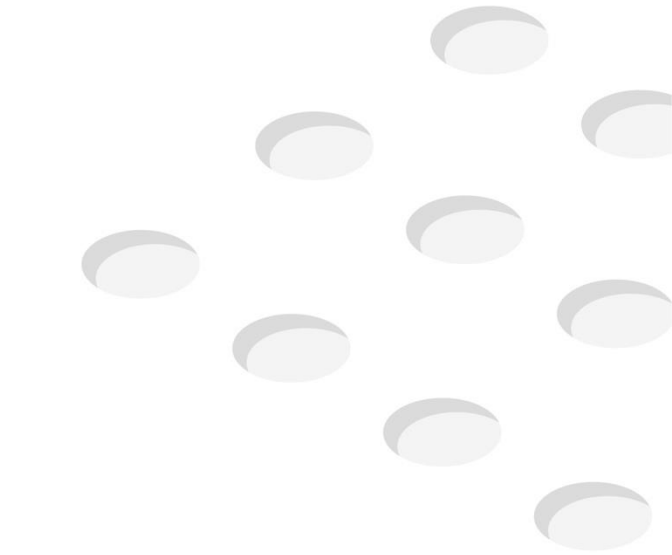
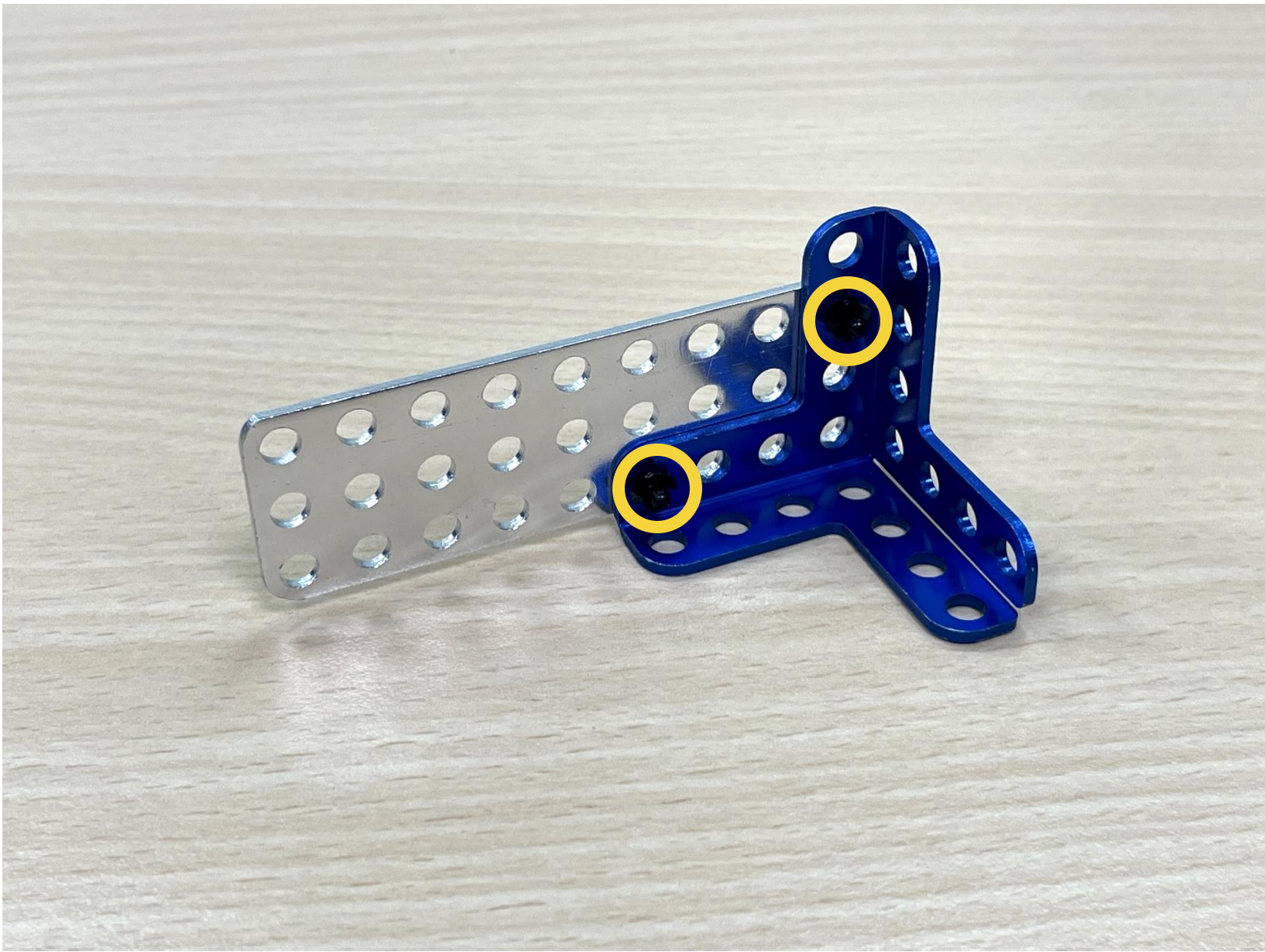

x1



x2

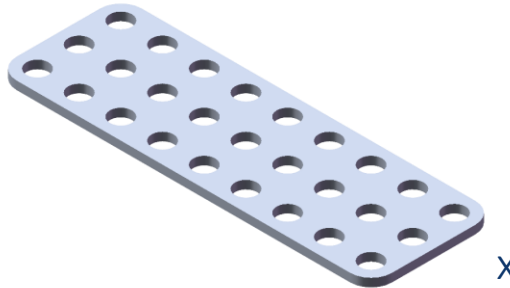

x1

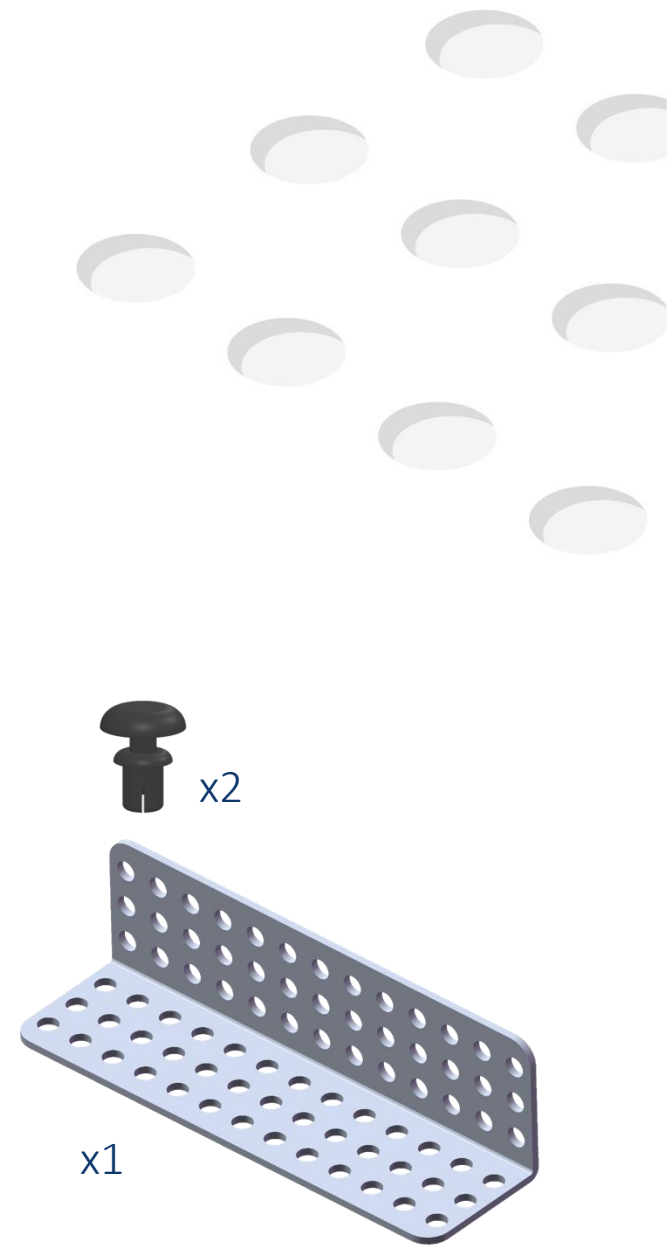
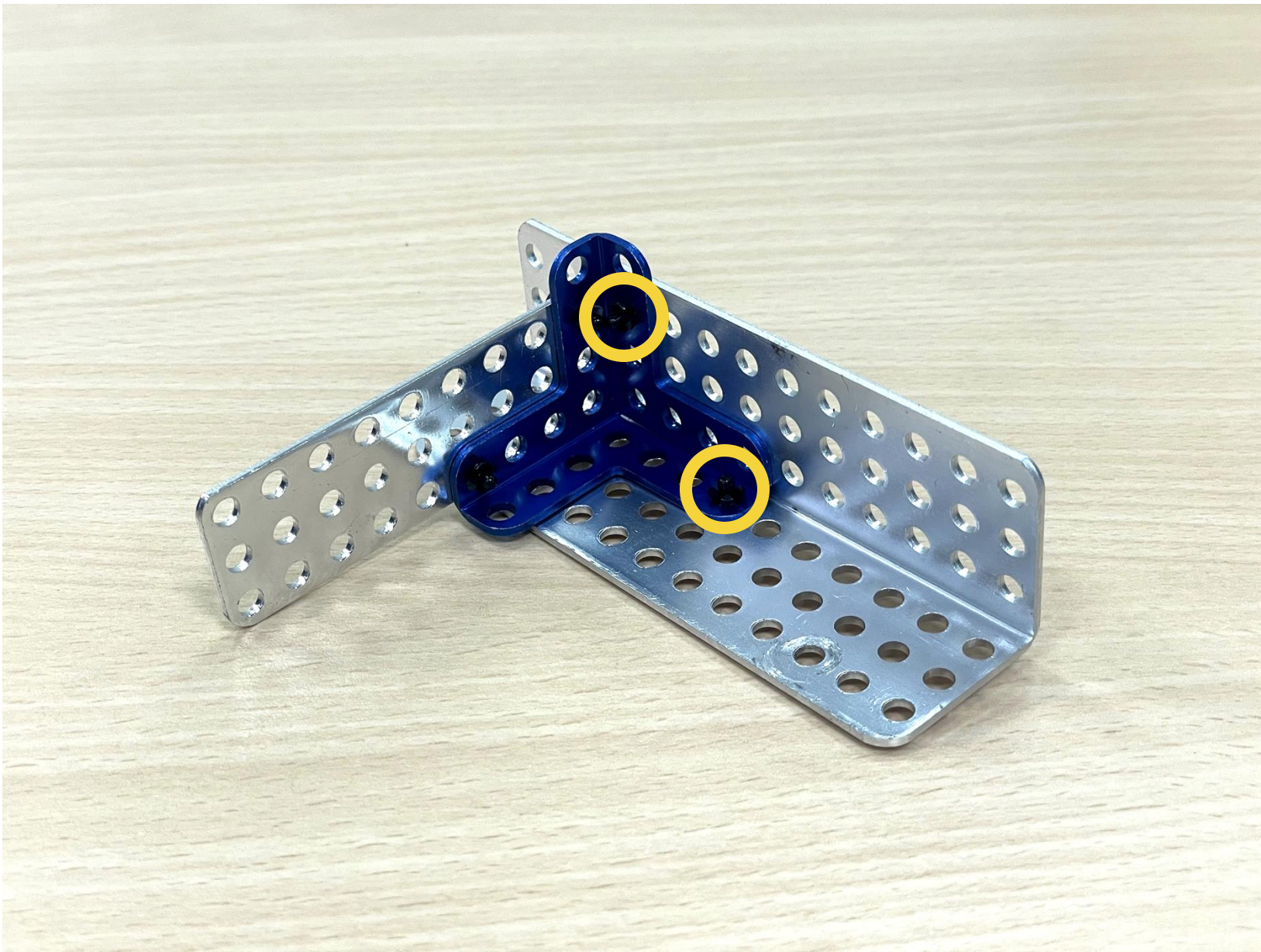

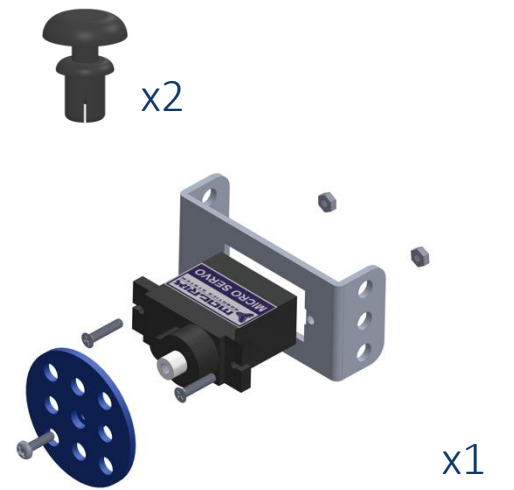
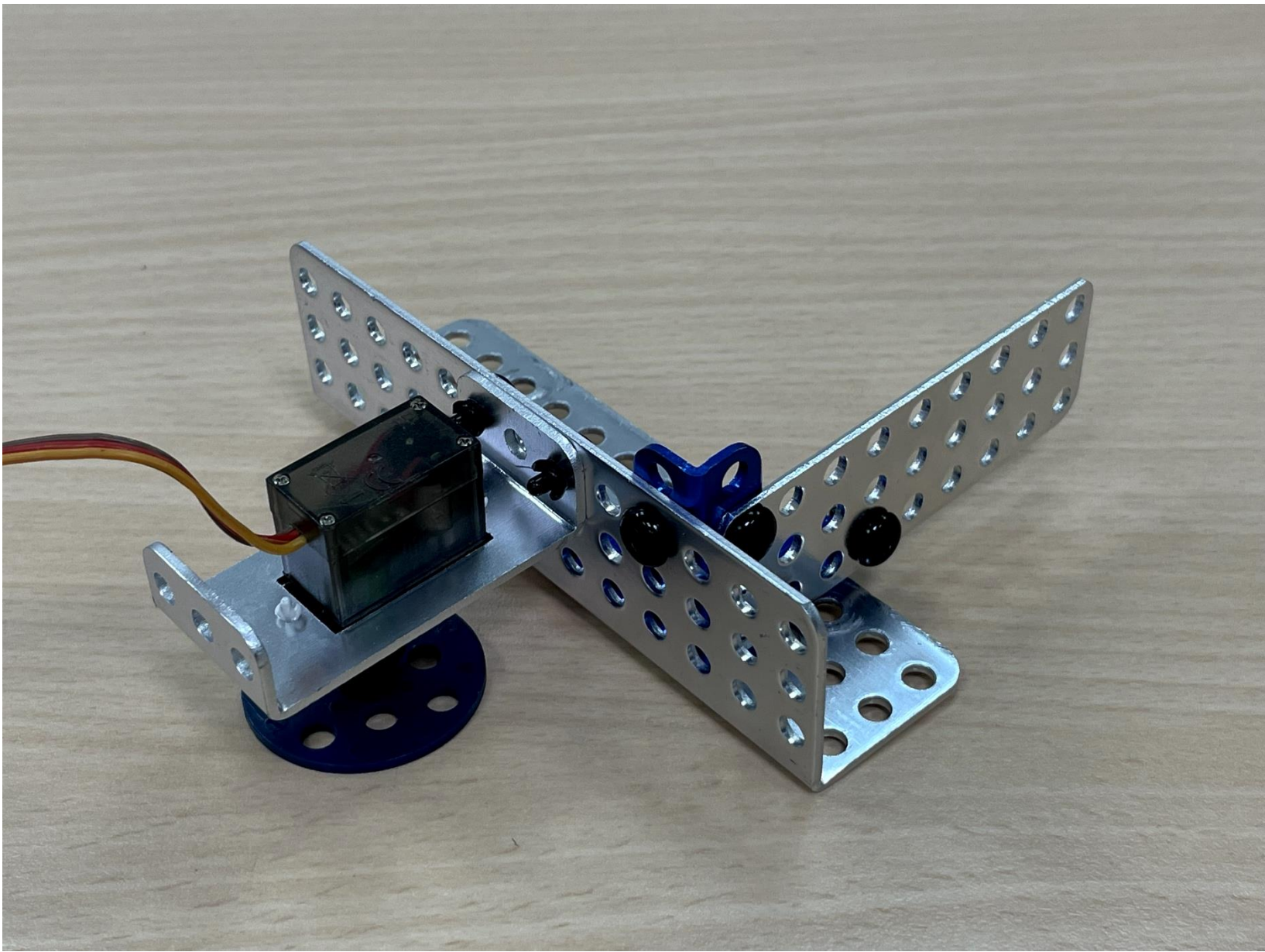

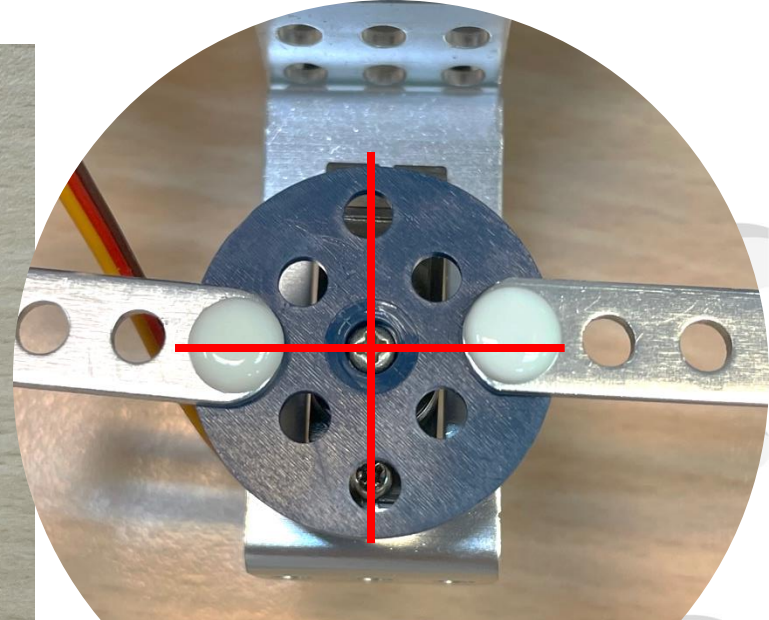
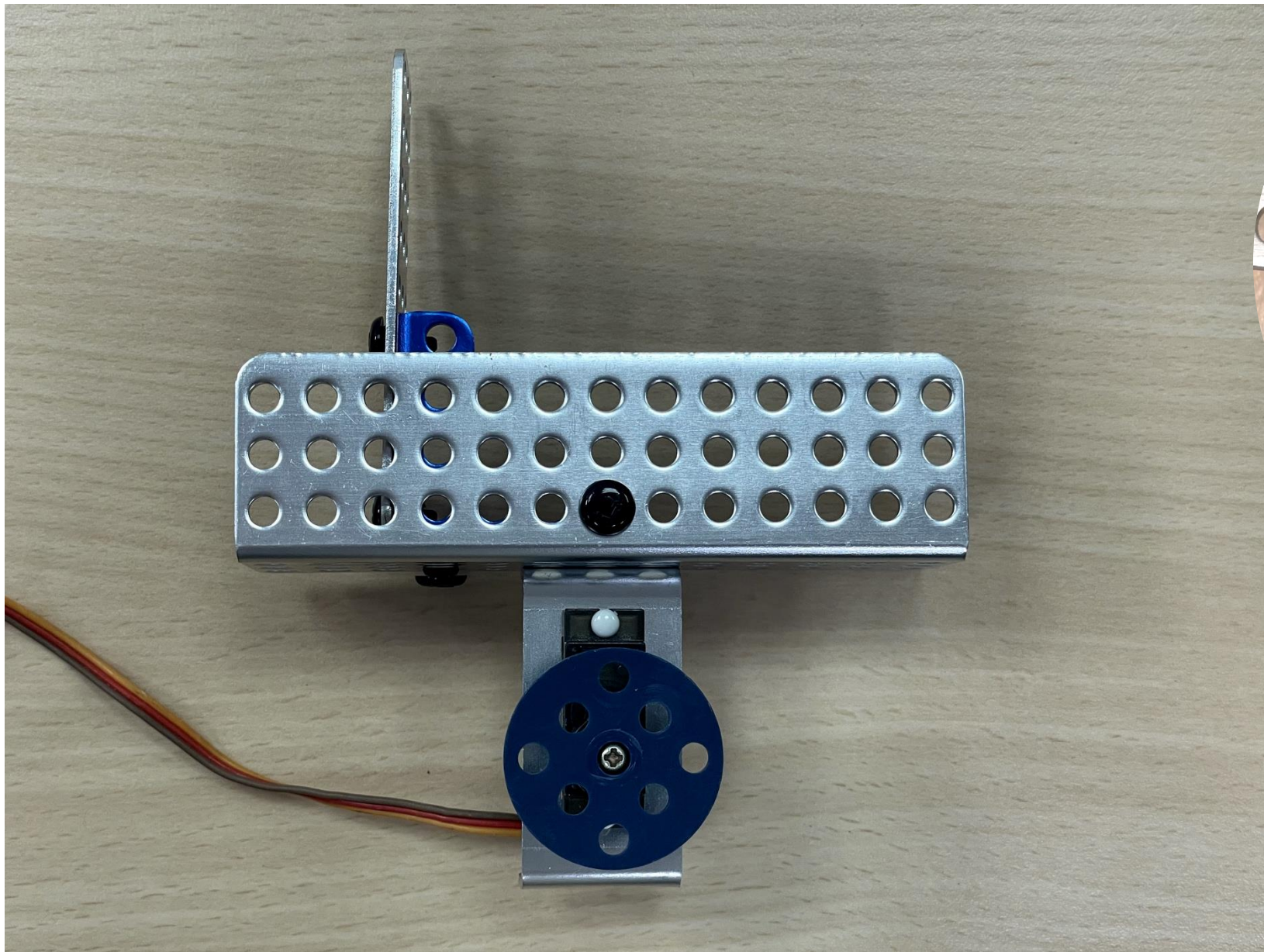

將舵盤逆時針旋轉到底
再調整至圖片上相同方向

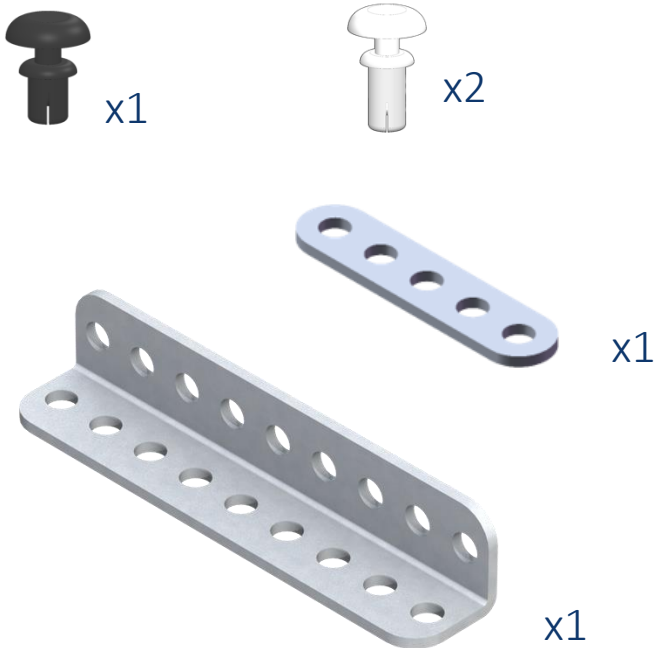
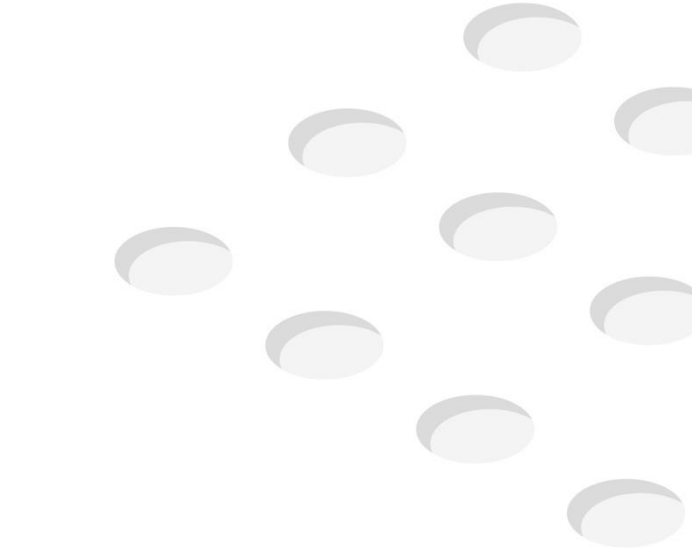
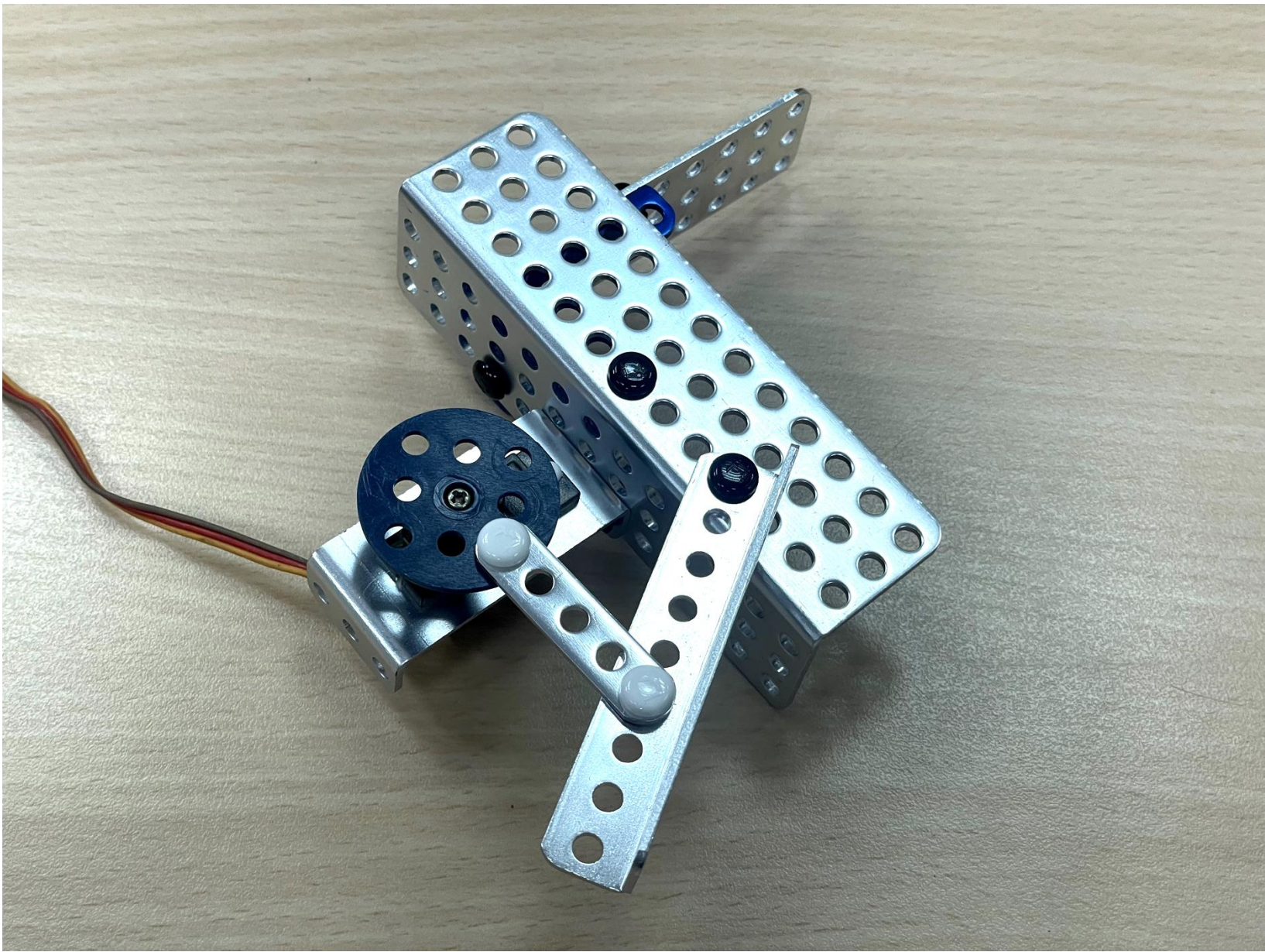

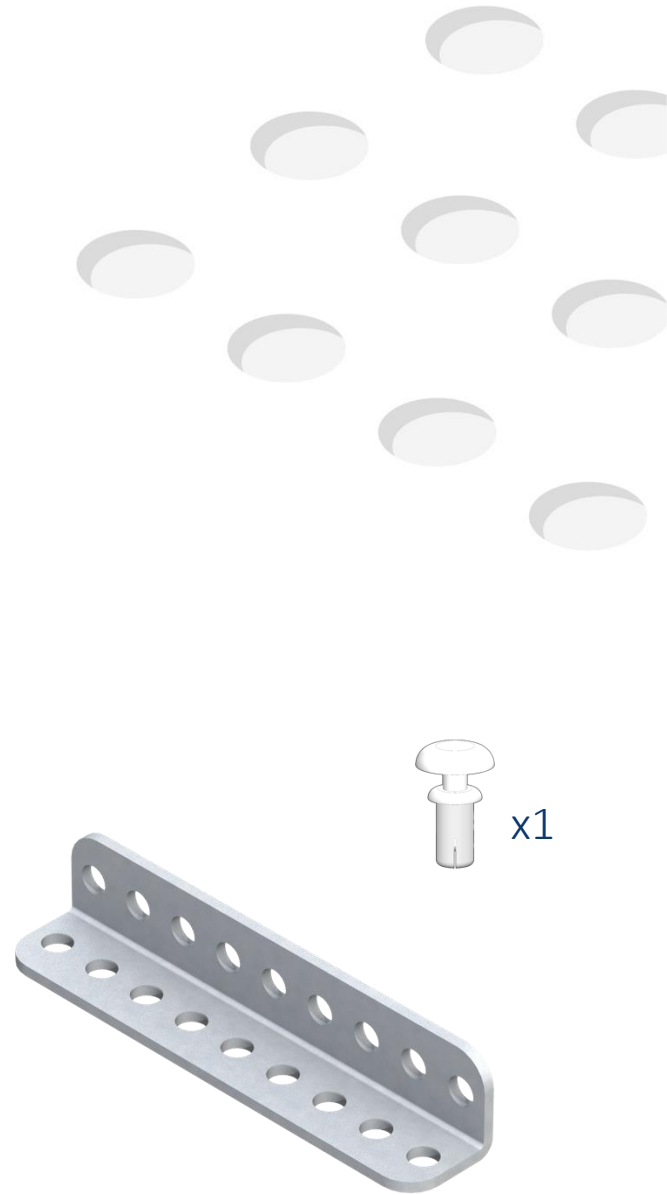
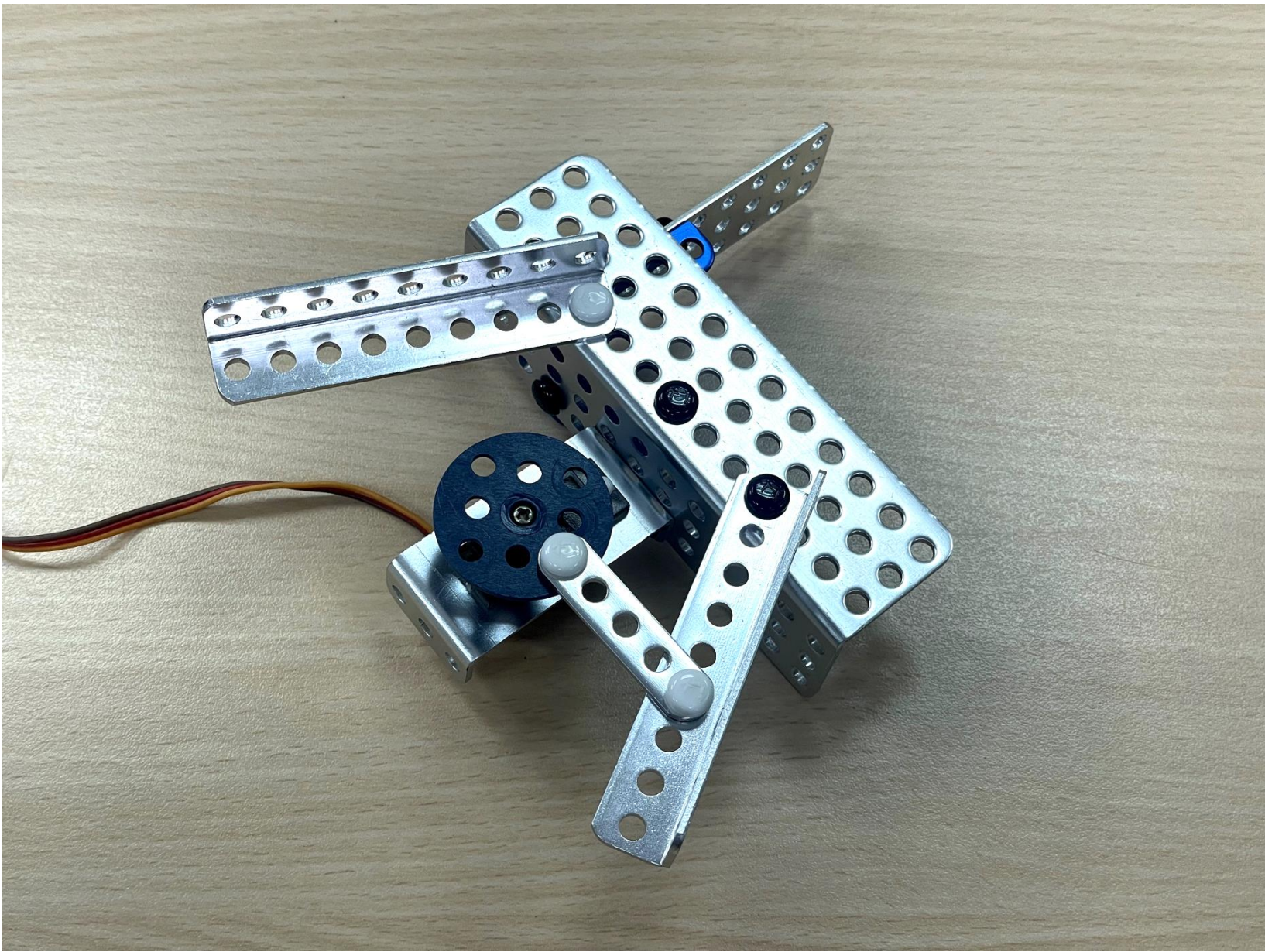

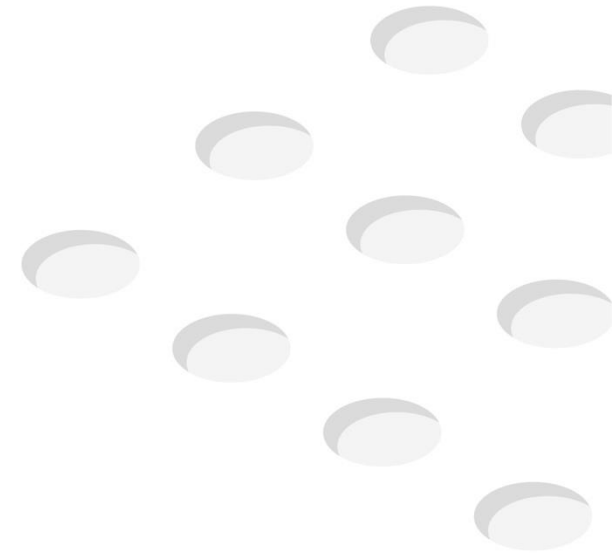
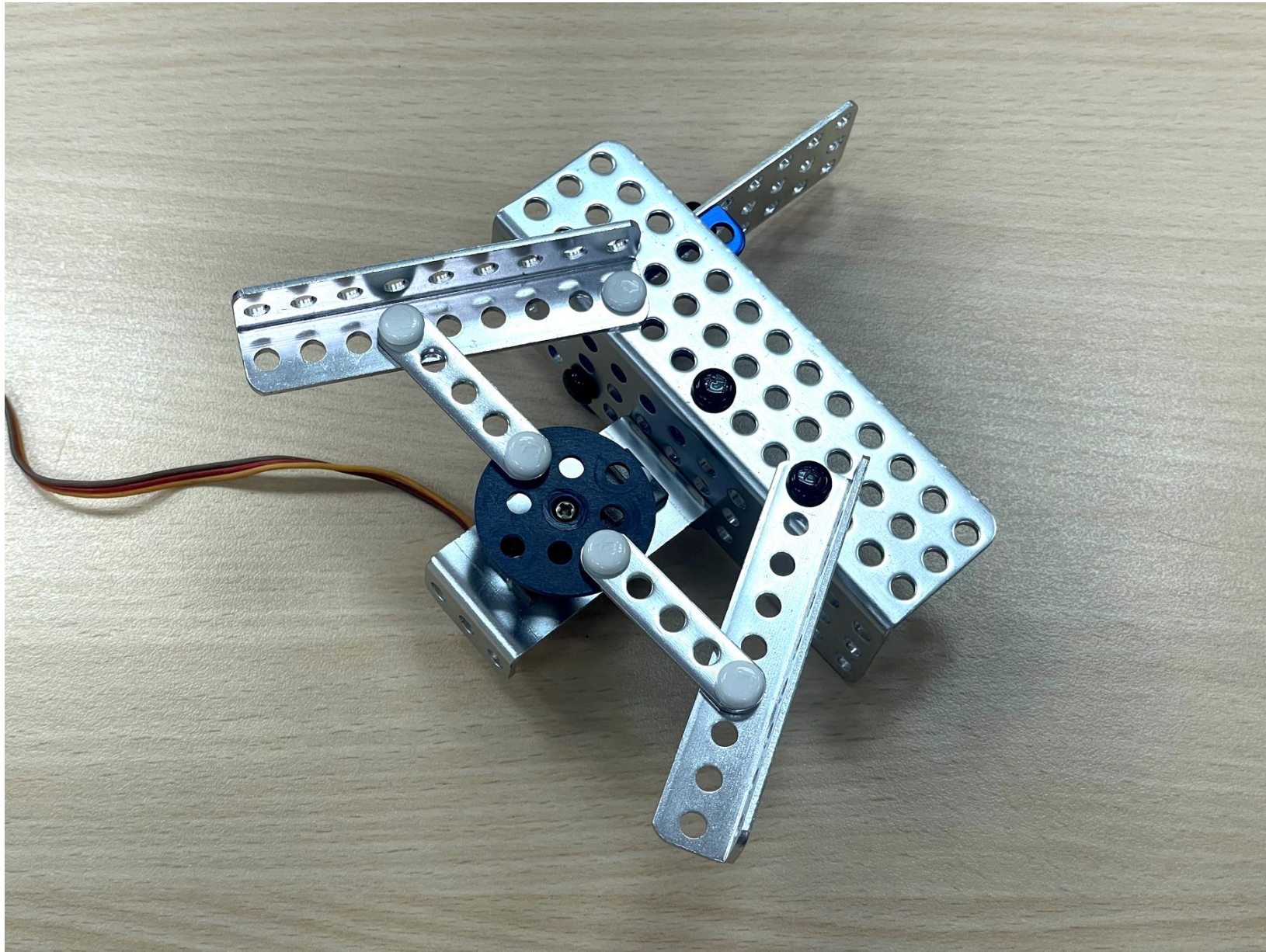

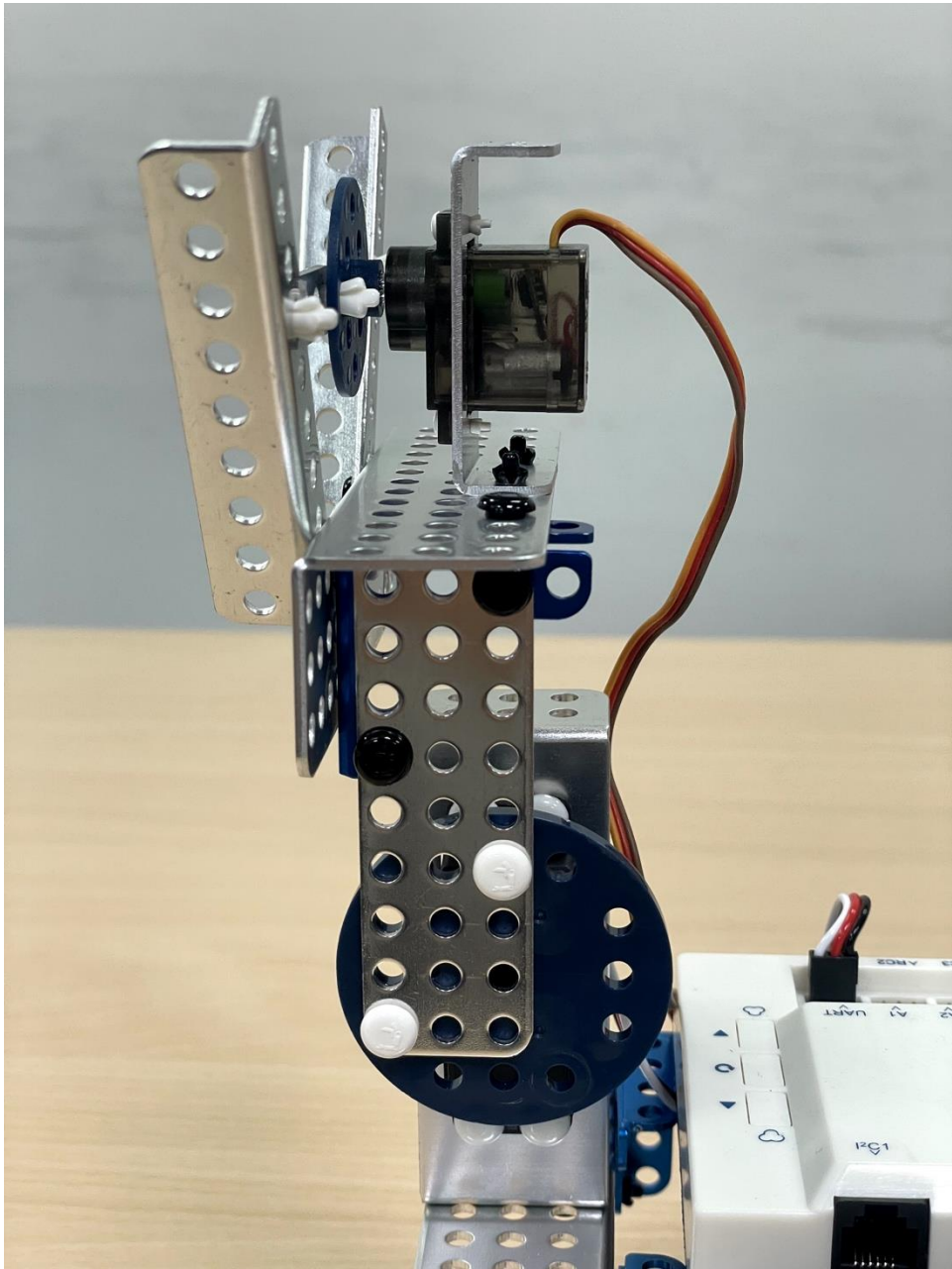

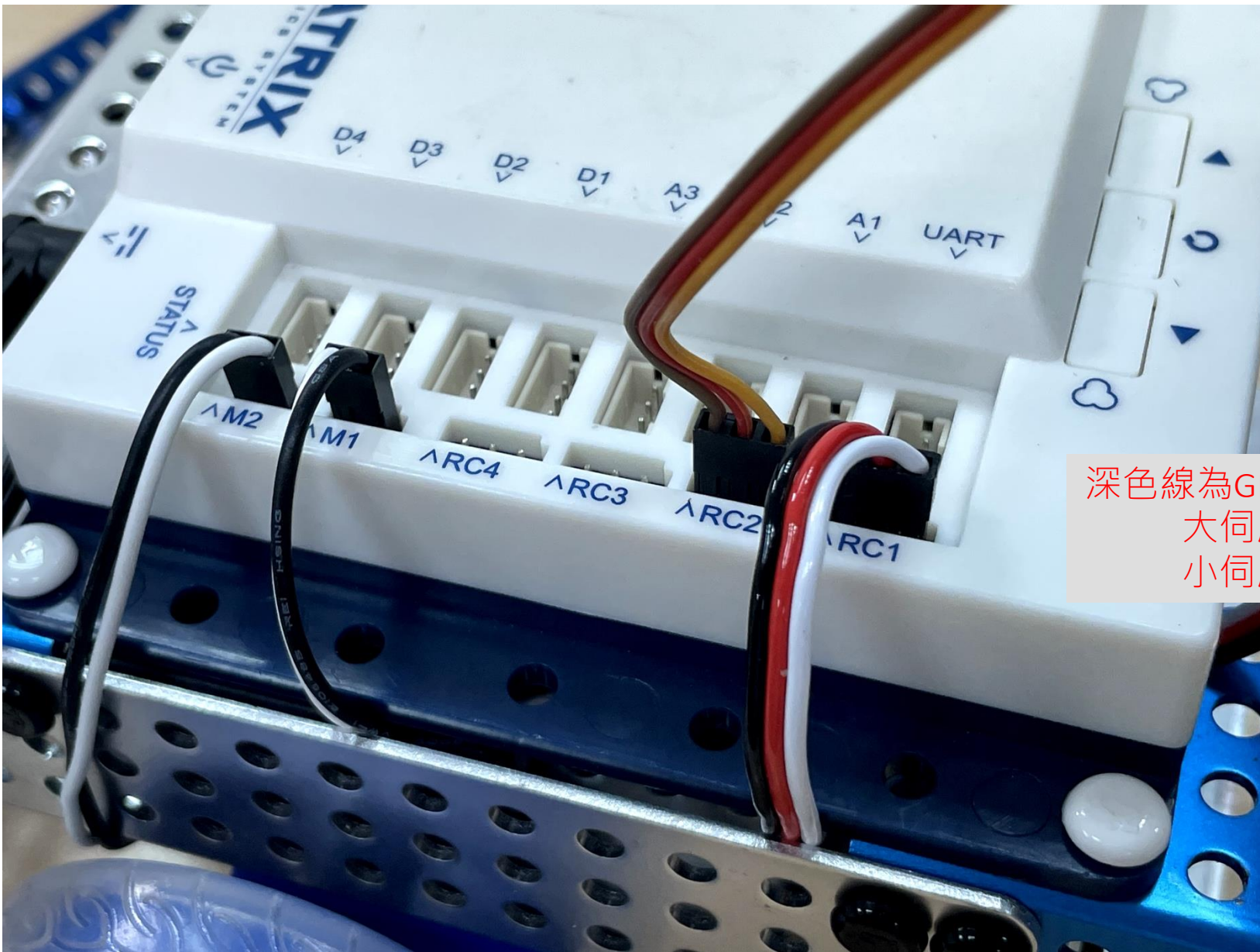

深色線為GND；GND靠R旁邊的^
大伺服馬達接在RC1
小伺服馬達接在RC2

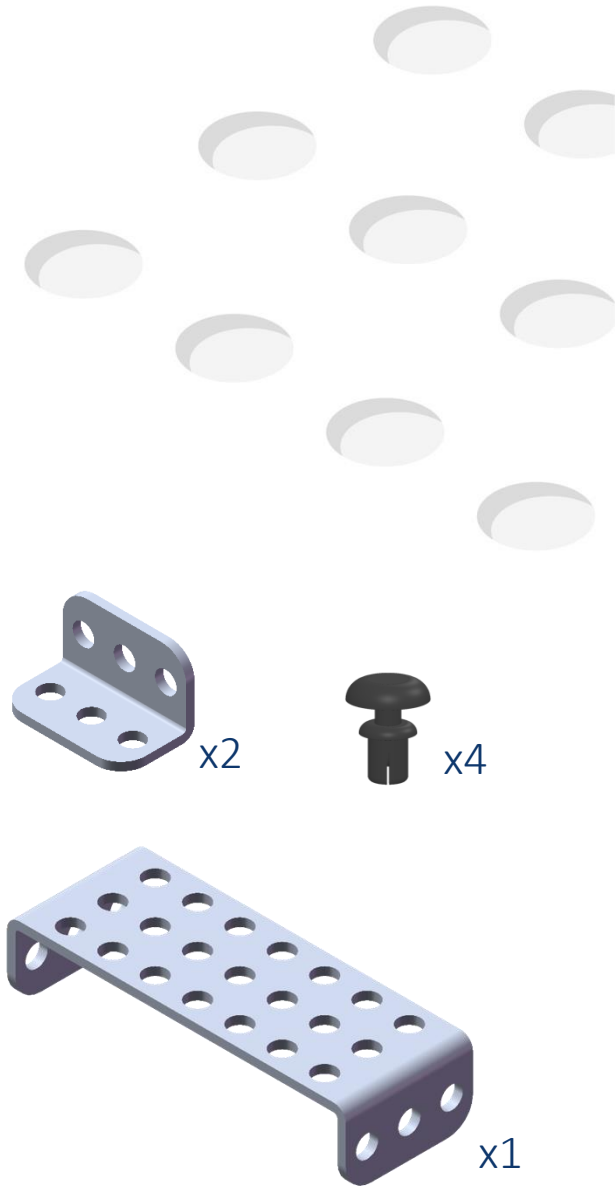
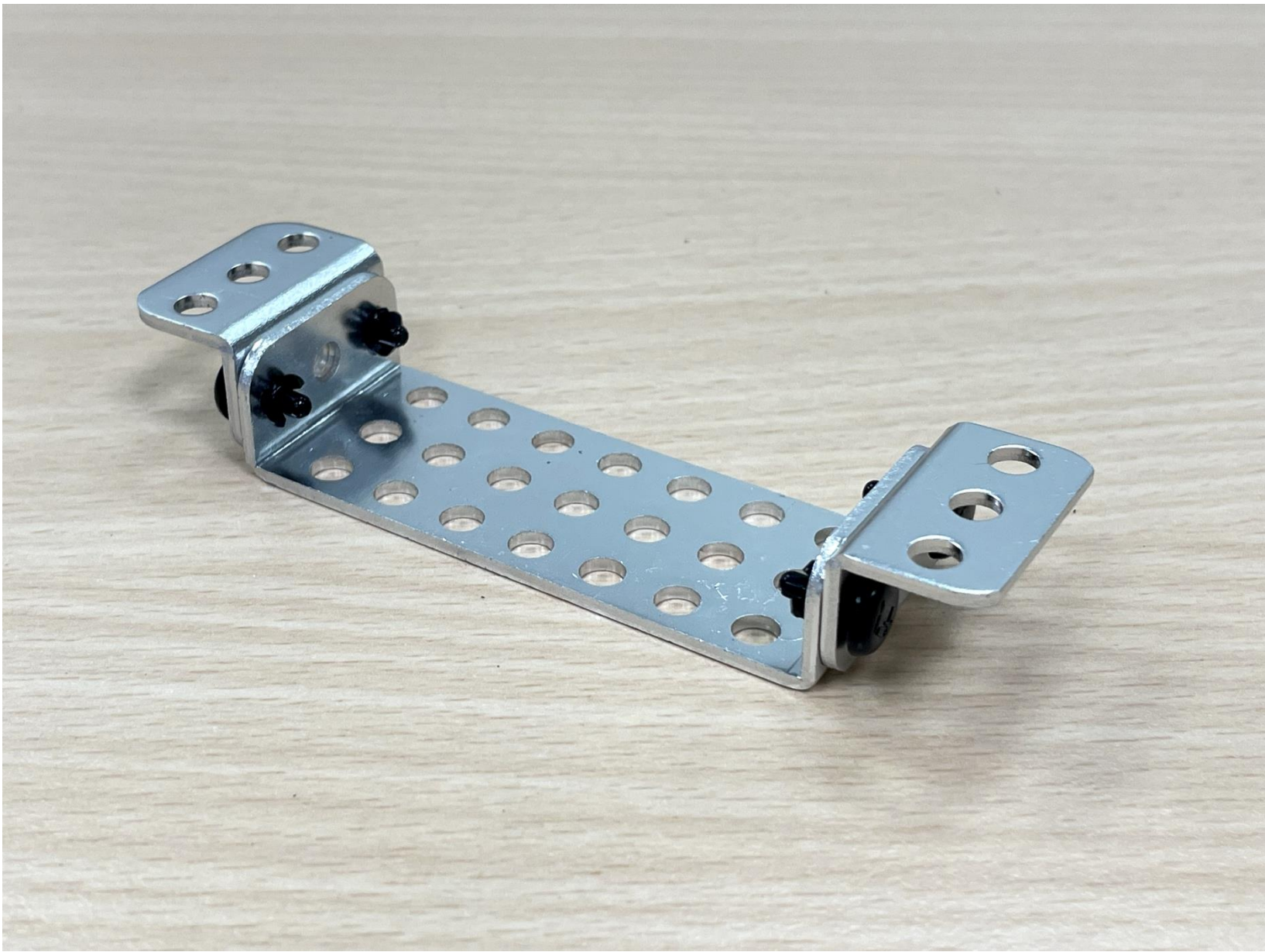

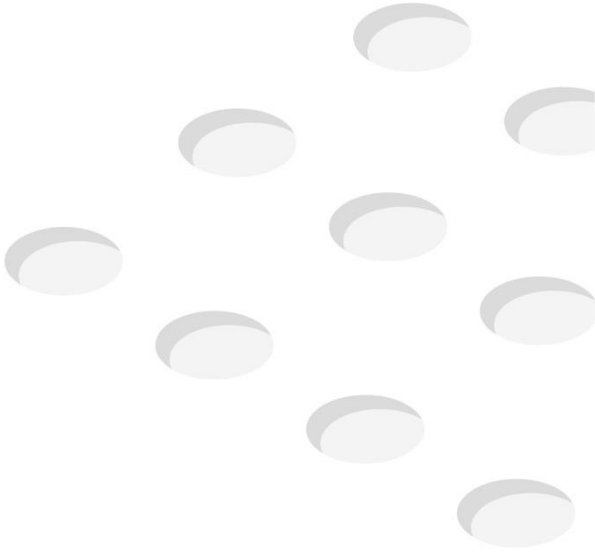
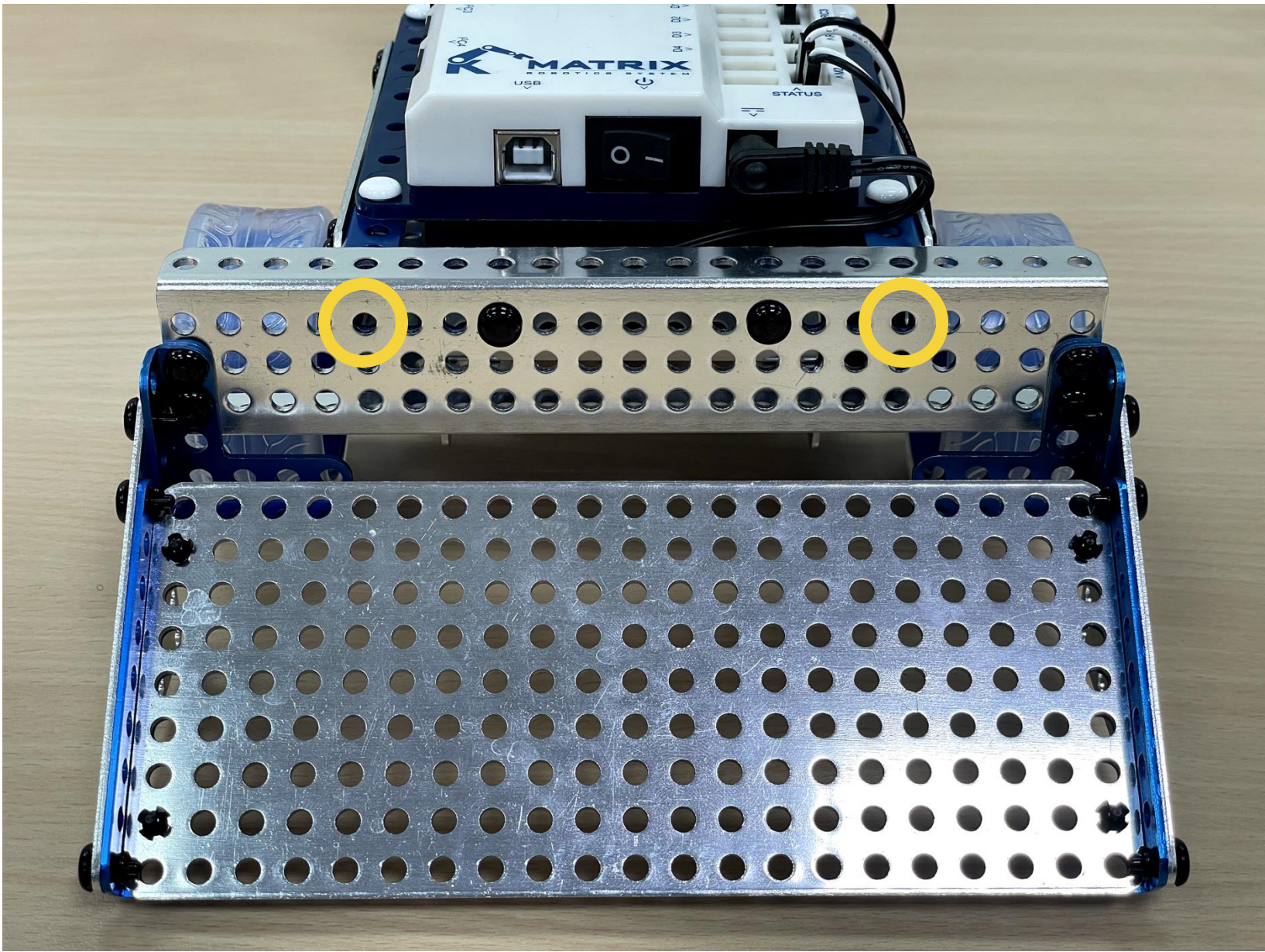

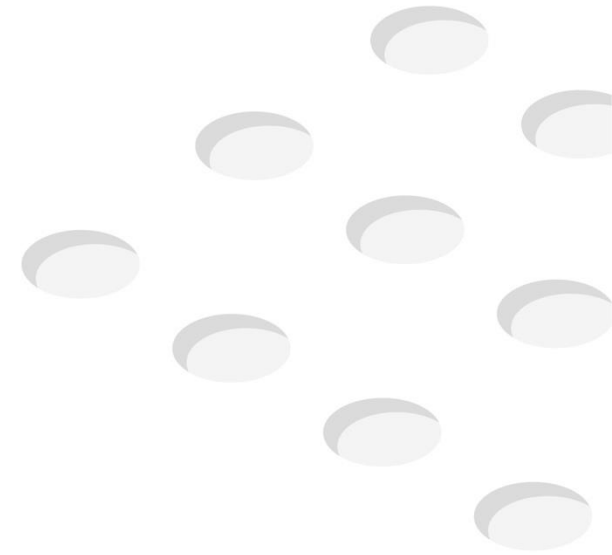
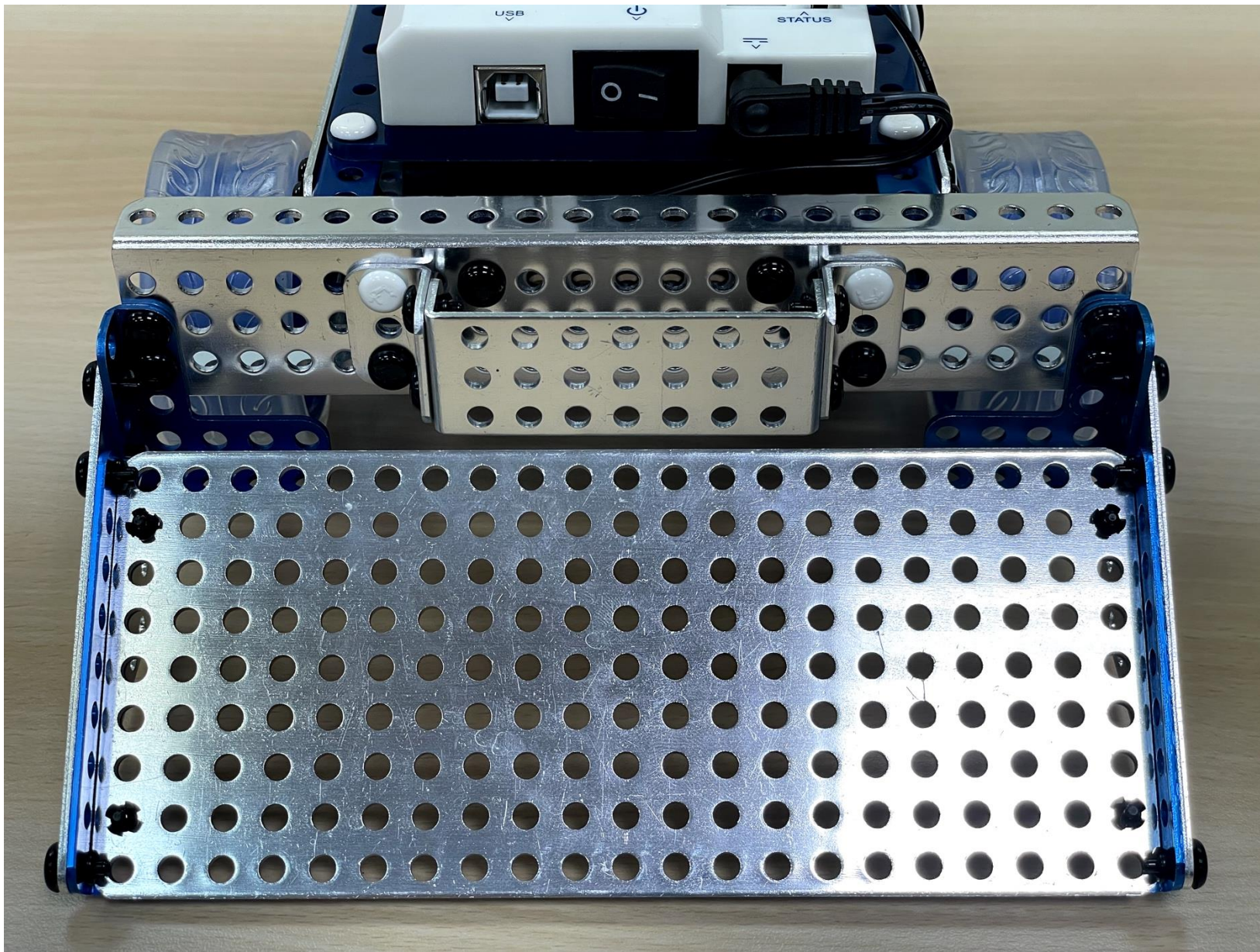

藍芽接收器連線方式

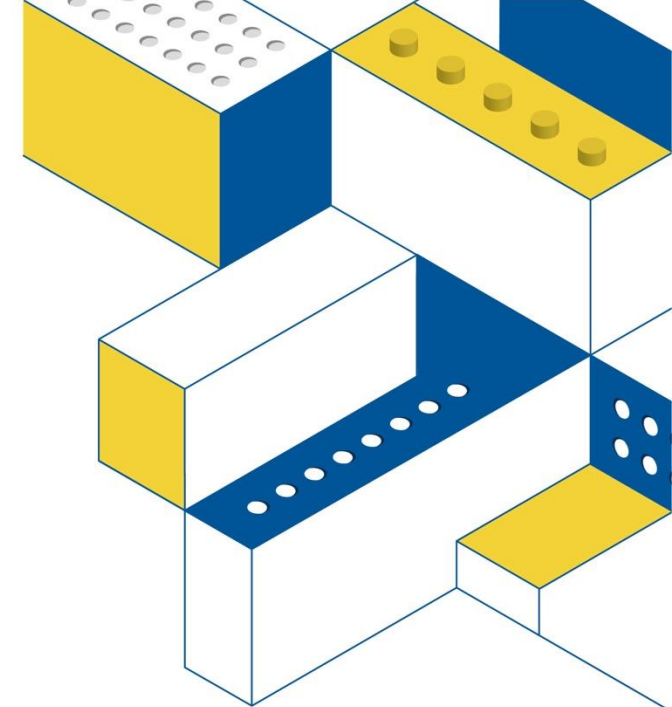
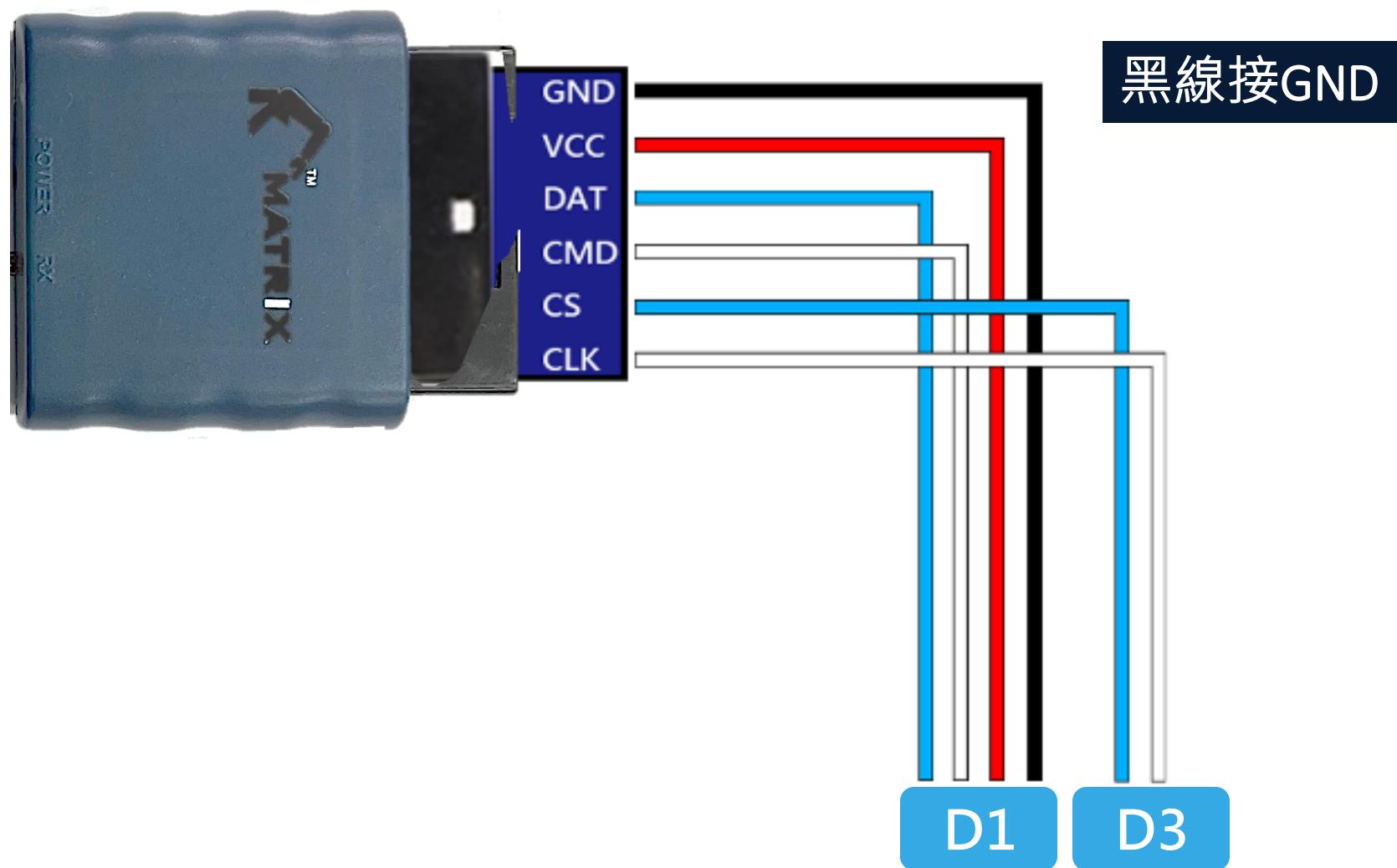

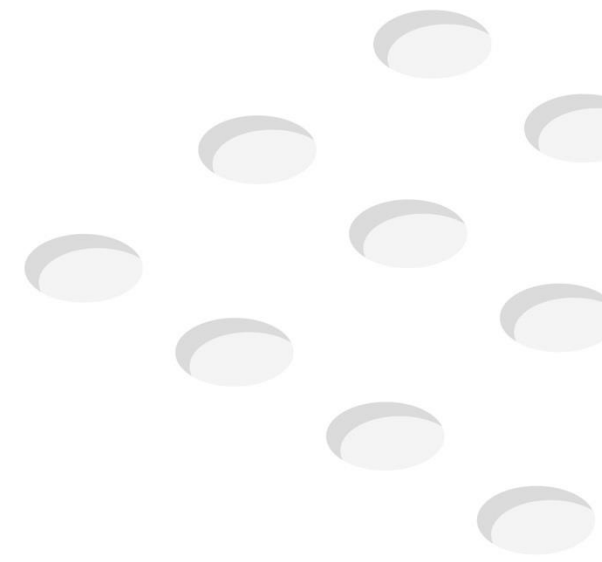
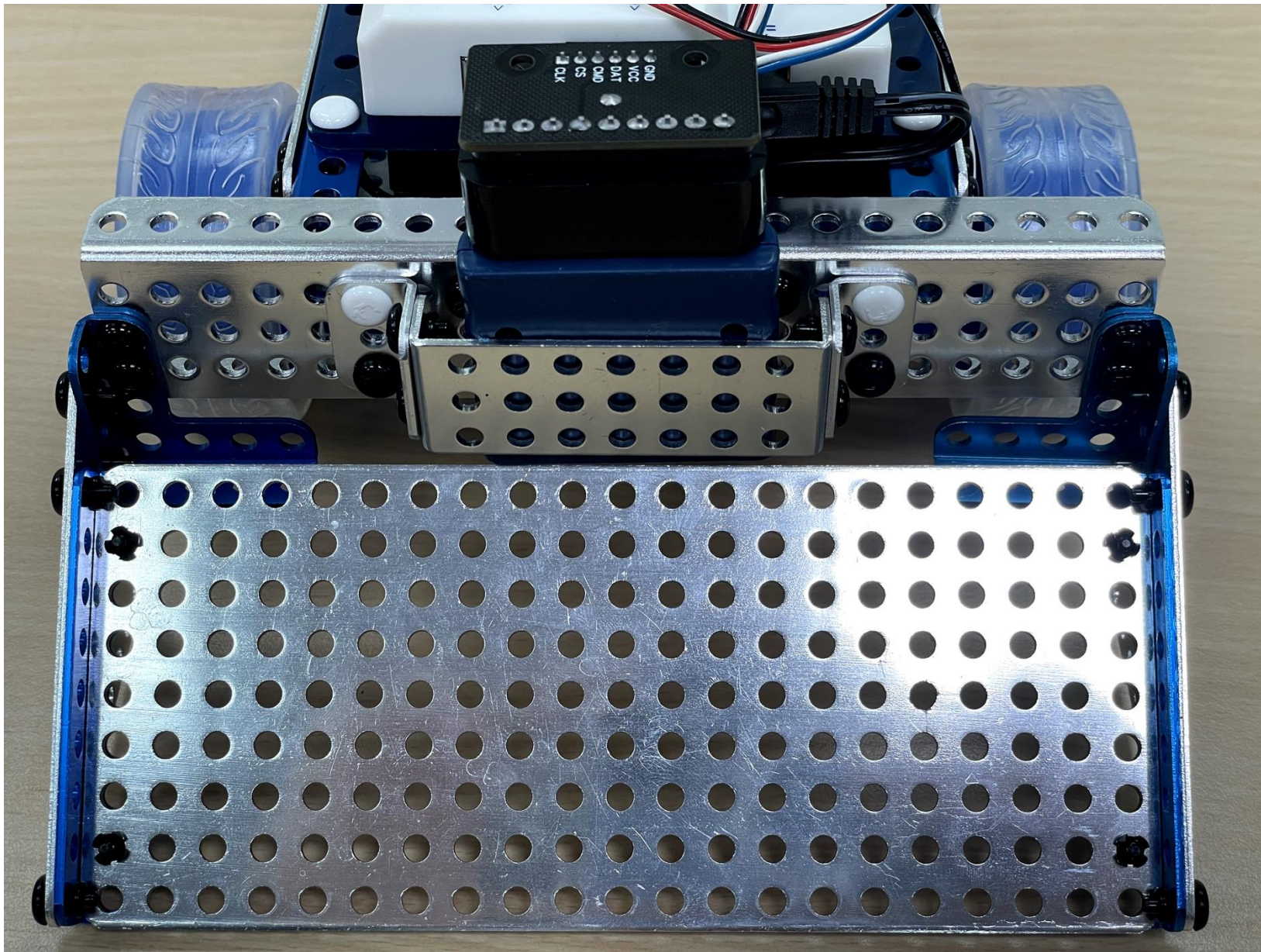

STEAM EDUCATION, FUTURE TECHNOLOGY.
